

TELSTRA BUSINESS SIP[®] INSTALLATION GUIDE

Published August 2019



Intentionally blank



Introduction	7
Document Scope.....	7
How to use this guide.....	7
Business SIP installation - document map	8
1 Site Preparation	9
2 Pre-Installation.....	9
3 Quick Installation Guides.....	10
3.1. Network-side installation configuration of SIP NTU	10
3.2. SIP NTU to PBX-side configuration (customer responsibility).....	11
3.3. Number Migration/Activation (customer responsibility)	12
4 SIP NTU Physical installation.....	13
4.1. SIP NTU ports.....	13
4.1.1. SIP NTU port descriptions	15
5 SIP NTU Network-side configuration (Northbound).....	16
5.1. SIP NTU login	16
5.1.1. SIP NTU username and password	16
5.1.2. SIP NTU password change	17
5.1.3. Static Ethernet IP & WAN discovery using the Provisioning Wizard.....	18
5.1.4. SIP NTU registration to the Business SIP Platform	20
5.1.5. Verification of the network-side (Northbound) configuration	22
6 SIP NTU to PBX-side configuration (Southbound)	23
6.1. Pre-PBX-side configuration considerations	23
6.2. SIP NTU login	23
6.3. Confirm SIP NTU network-side (Northbound) status.....	24
6.4. Selecting the 'PBX Type'	25
6.5. SIP NTU to ISDN BRA/BRI PBX.....	26
6.5.1. ISDN BRA/BRI configuration (Example One425)	26
6.5.2. BRA/BRI 'Physical Port Settings'	27
6.5.3. BRA/BRI 'ISDN Settings'	27
6.5.4. DID/Multi-number	28
6.6. SIP NTU to ISDN PRA/PRI PBX.....	29
6.6.1. ISDN PRA/PRI configuration	29
6.6.2. PRA/PRI 'Physical Port Settings'	30
6.6.3. PRA/PRI 'ISDN Settings'	30
6.6.4. PRA/PRI 'Timeslot Allocation'	31
6.6.5. ISDN PBX configuration completion	31



6.7.	SIP NTU to IP PBX.....	32
6.7.1.	SIP PBX Configuration	33
6.7.2.	PBX Profile.....	35
6.7.3.	IP PBX Topology and configuration.....	35
6.8.	SIP NTU configuration status verifications.....	39
6.8.1.	ISDN PBX status verifications	39
6.8.2.	IP PBX status verification	41
6.9.	Test Call from SIP NTU	42
6.9.1.	Test call instructions.....	42
6.9.2.	Test Result	42
6.10.	SIP NTU Administration.....	43
6.10.1.	Provisioning Server	43
6.10.2.	User Management.....	43
6.10.3.	Device Reboot.....	44
6.10.4.	Factory Reset.....	44
7	Number migration	45
7.1.	Business SIP – Customer Management Portal Administrator login	45
7.2.	Activations (number migration).....	46
7.2.1.	Rolling back your migration	47
7.2.2.	Number migration test calls.....	47
7.2.3.	Activation (number migration) process	49
8	Appendices	59
8.1.	SIP NTU Diagrams & Connections	59
8.1.1.	2515 IP PBX only	59
8.1.2.	270 IP & ISDN PBX.....	60
8.1.3.	420 IP PBX only	61
8.1.4.	425 IP PBX only	62
8.1.5.	425 4B 4TE IP & ISDN PBX.....	63
8.1.6.	540 IP PBX only	64
8.1.7.	700 IP & ISDN PBX.....	65
8.2.	Appendix - Retrieving NTU Device ID and password	66
8.3.	Appendix - Troubleshooting	67
8.4.	Appendix - SIP NTU LED functions/colour indicators.....	69
8.5.	Appendix – Faulty hardware.....	69
9	Glossary.....	70



Table of figures

Figure 1: Business SIP Solution Overview	7
Figure 2: Document Map	8
Figure 3: SIP NTU Port Layout Example	13
Figure 4: SIP NTU Interconnectivity Map.....	14
Figure 5: SIP NTU login page	16
Figure 6: SIP NTU password change	17
Figure 7: Starting the provisioning wizard	18
Figure 8: Static Ethernet IP option	18
Figure 9: Static Ethernet IP fields.....	18
Figure 10: Ethernet WAN detected	19
Figure 11: Ethernet WAN confirmed	19
Figure 12: Enter Business SIP Platform Device ID and Password.....	20
Figure 13: Voice interface registered with the Business SIP Platform.....	21
Figure 14: Confirming SIP NTU network-side (Northbound) configuration	22
Figure 15: SIP NTU login page	23
Figure 16: Initial status screen confirming SIP NTU provisioning.....	24
Figure 17: SIP PBX Selection	25
Figure 18: PBX status screen confirming PBX type selected	25
Figure 19: BRA/BRI port selection	26
Figure 20: Assigning numbers.....	28
Figure 21: PRA/PRI configuration groups	29
Figure 22: Recommended PRA/PRI Timeslot Allocation settings	31
Figure 23: ISDN PBX configuration confirmation	31
Figure 24: SIP PBX Selection	32
Figure 25: SIP PBX Configuration Page	33
Figure 26: SIP PBX Advanced Settings Configuration Page	34
Figure 27: SIP PBX Profile Selection	35
Figure 28: IP PBX Attached to SIP NTU Topology	35
Figure 29: Steps to configure PBX Attached to SIP NTU Topology	36
Figure 30: IP PBX - NTU Attached Settings.....	36
Figure 31: IP PBX Attached to Gateway Topology	37
Figure 32: Steps to configure PBX Attached to Gateway Topology.....	37
Figure 33: IP PBX - Gateway Attached Settings	38
Figure 34: Northbound and Southbound verifications.....	39
Figure 35: BRI ports verification	40
Figure 36: PRA/PRI ports verification	40



TELSTRA BUSINESS SIP®

Figure 37: SIP PBX Configuration	41
Figure 38: SIP Test Call	42
Figure 39: Test Call Results	42
Figure 40: Provisioning Server Synchronisation	43
Figure 41: User Management fields	43
Figure 42: Device Reboot option	44
Figure 43: Restore Factory Settings.....	44
Figure 44: Business SIP Portal Login Screen.....	45
Figure 45: Activations Tab	46
Figure 46: Migration process flow and test points	47
Figure 47: Activations (number migration) tab	49
Figure 48: View Affected Numbers pop-up	50
Figure 49: One2515 Series Front View.....	59
Figure 50: One270 front view	60
Figure 51: One270 1P AV2 5T/a rear view	60
Figure 52: One420 Series Front View.....	61
Figure 53: One420 AV2 4TE Rear View	61
Figure 54: One425 Series Front View.....	62
Figure 55: One425 4TE rear view	62
Figure 56: One425 Series Front View.....	63
Figure 57: One425 4TE Rear View	63
Figure 58: One540 Series Front View.....	64
Figure 59: One540 AV2 5TE/a Rear View	64
Figure 60: One700 front view	65
Figure 61: One700 2P AV2 5T/a rear view	65
Figure 62: Get Credentials link in SIP NTU tab.....	66
Figure 63: 'Get Credentials' pop-up example.....	66

List of Tables

Table 1: Recommended BRA/BRI Physical Port Settings	27
Table 2: Recommended BRA/BRI ISDN Settings.....	27
Table 3: Recommended PRA/PRI Physical Port settings	30
Table 4: Recommended PRA/PRI 'ISDN Settings'	30

Introduction

The Business SIP product is designed to be installed over any type of internet connection fixed or mobile broadband. It employs a SIP NTU (network termination unit) that connects to the internet and the PBX requiring a two stage configuration.

The SIP NTU internet configuration can be performed either by Telstra technicians, appropriately skilled customer technicians or Telstra nominated partners.

The SIP NTU PBX configuration can only be performed by PBX technicians.

Below is a simplified view of a Business SIP solution.

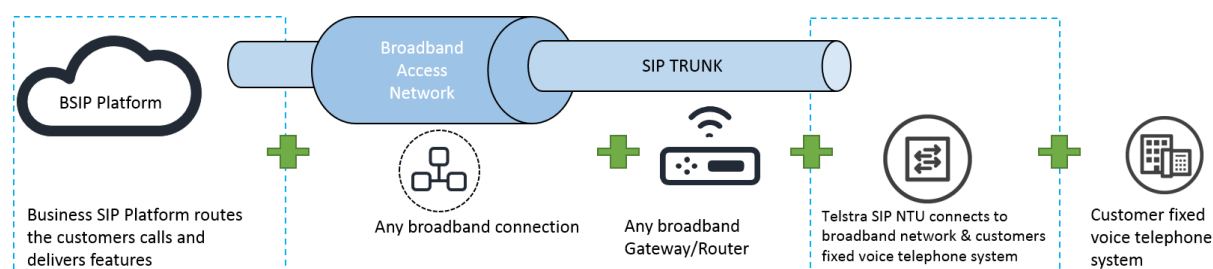

Figure 1: Business SIP Solution Overview

In the diagram above:

- 'SIP Trunk' refers to the IP connection which is provided over a fixed or mobile broadband service provided by the customer and identified above as 'Broadband Access Network'.
- 'Broadband Gateway/Router' is a customer supplied device that connects the 'SIP Trunk' to the 'SIP NTU'.
- 'Customer fixed voice telephone system' refers to the customers' own voice equipment such as a Private Branch Exchange (PBX) or Key Telephony System (KTS).

DOCUMENT SCOPE

This document covers the:

- physical installation of the SIP NTU (referred to as the 'device')
- configuration/registration of the SIP NTU to the Business SIP Platform (Calling Platform)
- configuration of the SIP NTU to the PBX
- number migration (where applicable for a given installation).

HOW TO USE THIS GUIDE

The content in this guide will be relevant across a range of activities and should be available to any person responsible for the following, as each section focusses on specific actions that together enable the complete installation of a Business SIP service:

- Site preparation
- Pre-installation activities
- Physical installation
- Network side configuration
- PBX side configuration
- Number migration and testing.

The map below can help you navigate through the installation process outlined above:

BUSINESS SIP INSTALLATION - DOCUMENT MAP

This diagram maps out the stages of a Business SIP hardware installation, configuration and number migration. Sections indicated refer to detail contained in this document.

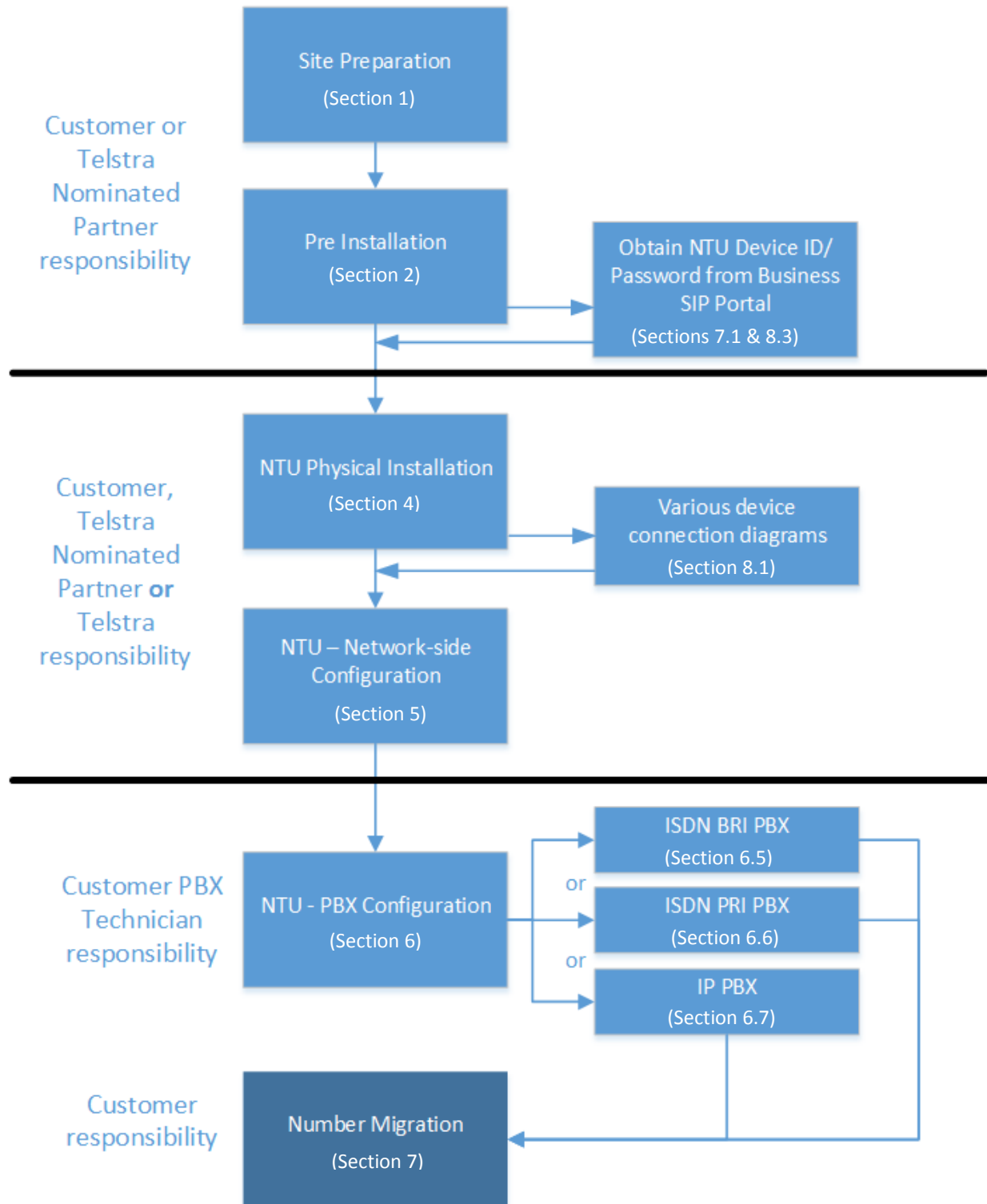

Figure 2: Document Map

1 Site Preparation

The following conditions should be observed when preparing the site and locating the equipment:

- Establish the IP addresses to be allocated to the devices being installed.
- Arrange for port forwarding on the router to be set up to ensure Telstra can remotely administer the SIP NTU. Further information can be found in the [Business SIP - Detailed Integration Guide](#). Failure to do so restricts Telstra's ability to assure the service remotely. As such, Fee For Service may apply if a Telstra technician is required or requested to attend site where port forwarding has not been setup.
- The device must be installed within two metres of a dedicated mains power outlet.
- The device will need shelving or desk space of approximately 300mm x 300mm, ensuring that there is sufficient ventilation. Do not stack devices directly on top of each other.
- Do not place the unit close to a heat source or in direct sunlight.
- Avoid locations exposed to heavy soiling due to exhaust from machinery, airborne particles from industrial processes or excessive dust.
- To ensure adequate airflow through the unit, please ensure that the ventilation holes are unobstructed at all times.
- Label any existing PBX cable(s) with the correct port number(s).
- Confirm that there will be a gateway device or internet access point that provides a working network connection, within 2 meters of the SIP NTU installation location.

2 Pre-Installation

Before commencing the installation:

- Check the SIP NTU to ensure that all components have been included and that the device has no obvious physical damage.
- Identify and reconfirm the gateway/internet access device that is providing a working network connection and that it is within 2 meters of the SIP NTU installation location.
- Obtain the device ID and password from the Business SIP Portal¹ using the login and password provided via email.
- Confirm that the old ISDN cable(s) are labelled with the correct port number(s).

¹ Access the [Telstra Business SIP Customer Management Portal](https://portal.mycalling.telstra.com/login) via the link (<https://portal.mycalling.telstra.com/login>). Once logged in, navigate to the 'SIP trunk' tab, then to 'SIP NTU' and select 'Get credentials'. Further details are available in the Business SIP Portal Administration Guide.

3 Quick Installation Guides

The following are quick guides that cover the three main aspects of installation, configuration and number migration.

The network side installation/configuration can be performed by Customer, Telstra nominated Partner or Telstra technicians.

3.1. Network-side installation configuration of SIP NTU

Step	Description	Section
1	Connect the SIP NTU to a power outlet. Leave switched off at the wall.	4 SIP NTU Physical installation
2	Connect from the WAN port of the SIP NTU (ETH 1/0) yellow cable, to a LAN port on the internet gateway. Switch the SIP NTU power on at the wall socket.	
3	Connect your laptop to the SIP NTU via a LAN port (use ports 0/2 or 0/3), open a browser and enter the IP address 192.168.9.1.	
4	Enter the ' user ' and ' password ' (these are case sensitive). Use values 'user' and 'password'; although the password may be the serial number from the bottom of the device.	5.1.1 SIP NTU username and password
5	Follow the prompts. Change the password to one agreed with the customer.	5.1.2 SIP NTU password change
6	Enter the password here: <input type="text"/> You'll be taken back to the login screen. Log in again and start the Provisioning Wizard.	
7	In the left menu, select ' Provisioning Wizard ', then select ' (-)Start '. Follow the prompts and enter the device ID and password ² . Click 'OK' as per the GUI prompts to connect to the DMS, which auto-downloads the configuration data and registers the device.	5.1.3 Static Ethernet IP & WAN discovery using the Provisioning Wizard 5.1.4 SIP NTU registration to the Business SIP Platform
8	As a final check, in the left menu of the web GUI, select ' Status ', ' (-)Voice ' and the SIP NTU Registration State field will show Registered . The AUX LED on the SIP NTU should be steady green.	5.1.4 SIP NTU registration to the Business SIP Platform

² The device ID and password (also known as DMS credentials) are located on the [Telstra Business SIP portal \(https://portal.mycalling.telstra.com/login\)](https://portal.mycalling.telstra.com/login). Once you log in, go to the 'SIP trunk' tab, then to 'SIP NTU' and select 'Get credentials'.

3.2. SIP NTU to PBX-side configuration (customer responsibility)

The PBX side configuration can only be performed by the Customer technician.

Step	Description	Section
9	Ensure that the existing ISDN PBX connections/cables are correctly labelled. As per steps 3-6, connect your laptop to the SIP NTU using ports 0/2 or 0/3 and login as per steps 4 to 6 but using the current password.	6.5 SIP NTU to ISDN BRA/BRI PBX 6.6 SIP NTU to ISDN PRA/PRI PBX
10	Select PBX Type and then either ISDN or Ethernet SIP on the web dropdown menu.	6.4 Selecting the 'PBX Type
11	Configure the BRA/BRI, PRA/PRI or IP ports using the recommended settings. If the optional steps are not required go to step 14.	6.5 SIP NTU to ISDN BRA/BRI PBX 6.6 SIP NTU to ISDN PRA/PRI PBX 6.7 IP PBX

Optional steps if the service is multi-number or line hunt/multi-number		Section
Provisioning Wizard – DID/Multi Number screen		
12	Select from the range of Unassigned Numbers on the web user interface.	6.5.4 DID/Multi-number
13	Drag and drop each number to the appropriate ports (the same ports as the existing ISDN PBX). If you have a number that you wish to hunt across the ports, assign it to the Line Hunt field.	6.5.4 DID/Multi-number

Step	NTU to PBX (Southbound) verification and prep for Number migration	Section
14	Confirm the completion of the PBX configuration using the SIP NTU GUI. Navigate to the ' Status ' / ' System Information ' / ' System Status ' section and look for ' PBX Configured ' Yes (Type xxxx)	6.8.1 ISDN PBX & 6.8.2 IP PBX
15	Prior to number migration prepare to disconnect the cables from the existing NT1s and connect to the appropriate SIP NTU BRA/BRI / PRA/PRI or Ethernet port/s.	n/a

3.3. Number Migration/Activation (customer responsibility)

The following is a summary of the steps required to migrate and test voice services between the PBX and the Telstra Business SIP platform, activities of which are the responsibility of the customer.

Step	Performing Number Migration/Activation	Section
16	Before starting the number migration ensure that the SIP NTU has been configured against the PBX. (See step 14 in the 'PBX-side configuration Quick Guide' section 3.2 above.)	3.2 Quick Guide
17	Using the Portal URL and login detail provided, access the Telstra Business SIP Customer Management Portal and navigate to the ' Activations ' tab.	7.2.3 Activation (number migration) process
18	Check the ' View Affected Numbers ' to confirm the numbers being migrated in the current order.	
19	If not done already, move the PBX cabling from the existing NT1 to the new SIP NTU device, noting that your services will cease to operate from this point until number migration is completed, or you move the cabling back to the NT1.	
20	Follow the screen prompts to activate the outbound numbers.	
21	Perform outbound test calls* from the PBX handset.	
22	Follow the screen prompts to activate the inbound numbers.	
23	Perform inbound test calls* to the PBX.	
24	Activate finalisation.	
25	It is advised to perform some load testing to ensure that your required concurrent call numbers are possible on your broadband service and that uploads and downloads are also unaffected. If you find that call quality is impacted, roll back the activation using the Business SIP Portal and address the issue before performing the Activation again.	
26	Once Activated and finalised, continue to use the new services (for seven days) taking note of and reporting any issues to Telstra. Both outbound and inbound services can be rolled back (using the Portal) within this time if issues are identified.	

*The test calls and the use of the Customer Management Portal user interface can be performed by a non-technical person, however some experience may be useful to communicate with Telstra support groups, should any issues arise.

4 SIP NTU Physical installation

The basic steps for connecting the SIP NTU are:

1. Connect the power plug to the back of the SIP NTU (**note whether the unit has an on/off switch and ensure that it is in the 'OFF' position**).
2. With the mains wall switch in the OFF position, connect the other end to the power outlet in the wall.
3. Connect the Ethernet cable (running from the LAN port on the gateway or NTD) to the Ethernet port 1/0 of the SIP NTU (**do not connect it to any of the ports in the four-port switch**).
4. **Connect the Ethernet cable from a PC/laptop to either LAN port 0/2 or 0/3 only.**
Note: Ports 0/0 through 0/3 will only provide access during initial device provisioning.
5. **Turn on the power at the wall and where applicable, switch on at the SIP NTU.**

Note: The SIP NTU will be powered up and ready for provisioning when the **STATUS** and **IP** LEDs are steady green.

4.1. SIP NTU ports

There are different types of connections on each of the SIP NTUs and this section presents and describes the differences between the connection types and their functions.

See Section 8.1 SIP NTU Diagrams & Connections for the connections and layouts for each model applicable to the Business SIP product.

A typical SIP NTU port layout could look like this:

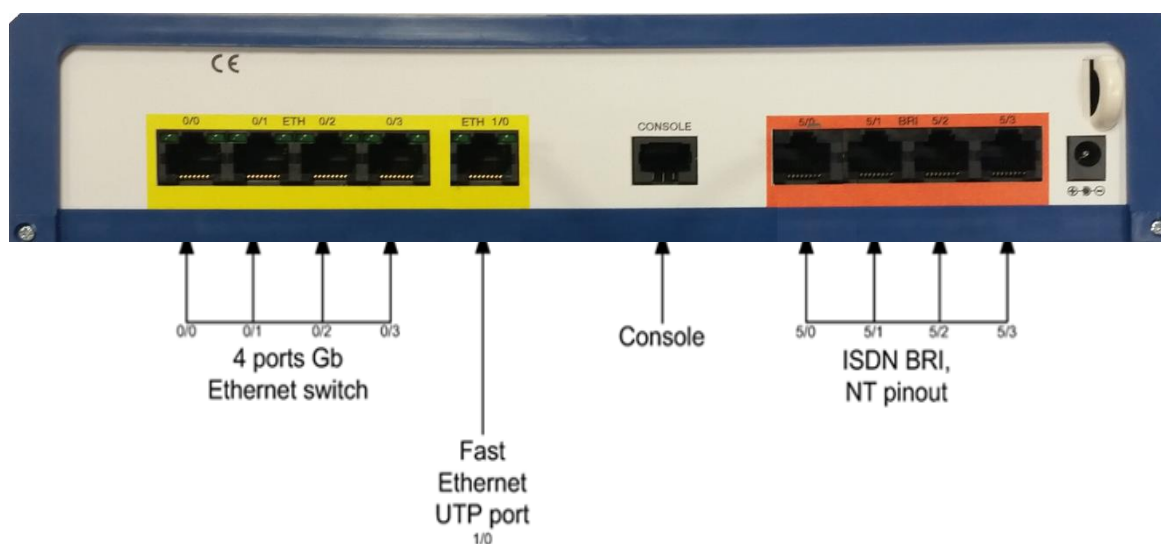

Figure 3: SIP NTU Port Layout Example

The port types found across the range of OneAccess SIP NTUs are described on page 15.

The image below shows the types of devices/systems that would be supported by each type of port.

Note: This is not intended to convey a typical installation configuration, but provides graphical information about where devices connect to the SIP NTU ports.

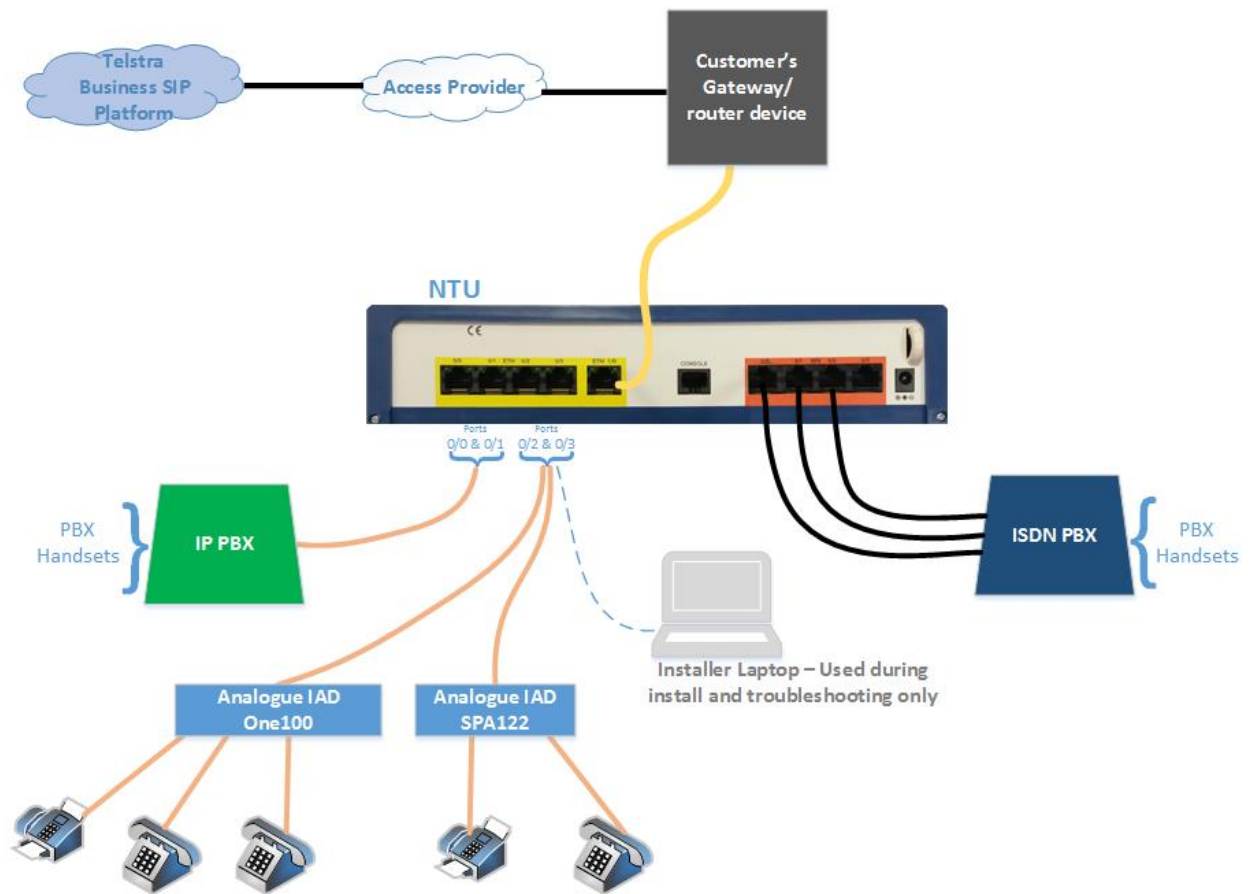









Figure 4: SIP NTU Interconnectivity Map

4.1.1. SIP NTU port descriptions

<p>Ethernet (LAN) Ports Ethernet ports supporting IP PBXs, analogue IADs and laptop connection for SIP NTU configuration and troubleshooting.</p> <p>Important: Ports 0/0 & 0/1 are for PBX's using static IP Ports 02/ & 0/3 are DHCP for IAD's, PBX's and PC's that are ok with dynamic IP's</p>	 <p>Ports 0/0 & 0/1 are static IP Ports 02/ & 0/3 are DHCP.</p>
<p>Fast Ethernet/UTP Port This port is used to connect the carriage service to the SIP NTU.</p> <p>This port can also be seen labelled as either ETH or UTP as shown here</p>	
<p>BRA/BRI & PRA/PRI Ports These ports support ISDN PBXs. There are three types of ISDN port configurations.</p> <p>BRA/BRI (4 Ports) and 2 PRA/PRI variants (1 port 5/0 and 2 port 5/0 & 5/1)</p>	 
<p>DSL, SFP and Console Ports</p> <p>The VDSL/ADSL port is not available on all models.</p> <p>The SFP and console connections are not used on any Business SIP installation.</p>	  

5 SIP NTU Network-side configuration (Northbound)

This section covers four main activities to configure the SIP NTU and register it with the Business SIP Platform:

1. Logging in to the SIP NTU GUI via the web browser interface (requiring a username and password)
2. Changing the default password (forced)
3. Using the '**Provisioning Wizard**' to detect the WAN
4. Register the SIP NTU with the Business SIP Platform (requiring the Business SIP Platform device ID and password also referred to as the Business SIP Platform credentials or just 'credentials'.)

5.1. SIP NTU login

On the laptop connected to port 0/2 or 0/3 on the SIP NTU, open a web browser and enter **192.168.9.1** to open the SIP NTU login page.



Figure 5: SIP NTU login page

5.1.1. SIP NTU username and password

Enter the username and password into the fields shown at right above. **Note: these detail are case sensitive.**

On first login, the Username field value is: "user" and the Password value will be 'password' (if this password fails try the serial number of the SIP NTU, which can be found on the label underneath the device. **Note:** This may only be applicable for earlier SIP NTUs configured for Business SIP.

There is a forced password change on first use for security purposes and this is covered in the next section.

5.1.2. SIP NTU password change

On first login you will see the following screen, prompting the password change. Ideally, the customer will provide this password.

Note: Telstra is not required to maintain a record of the new password.

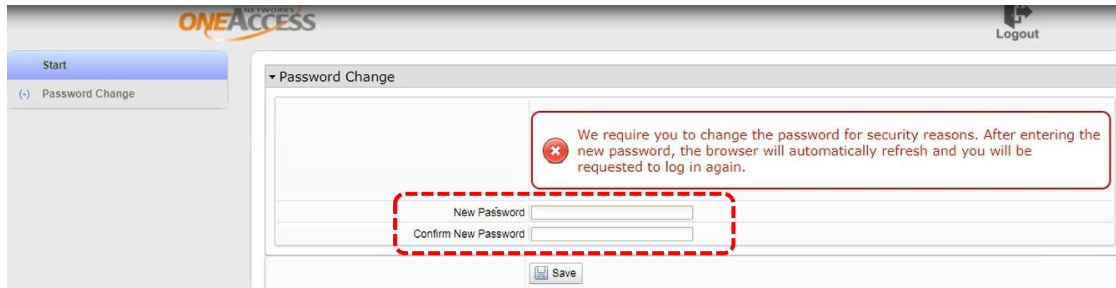
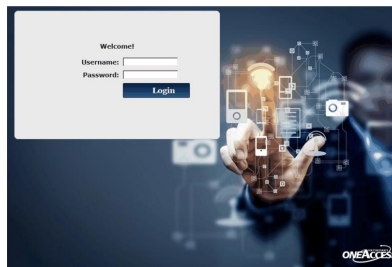

Figure 6: SIP NTU password change

Once the new password has been entered, the interface re-presents the login screen forcing the use of the new password.



Log in again using the new password and you will be presented with the system status screen, indicating that nothing has been started or configured.

Note: If there appears to be a delay in this page refreshing, perform a manual refresh F5 and the login page should present ready for the login and new password.

For password related issues contact Telstra on [1800 790 831](tel:1800790831).

5.1.3. Static Ethernet IP & WAN discovery using the Provisioning Wizard

The **'Provisioning Wizard'** allows you to set a static IP address if there is no DHCP server available. It also detects the WAN type, which is a critical step before it is then used to log in to the Business SIP Platform to download the configuration file for the device.

To begin, select **'Provisioning Wizard'** from the left menu pane, then click on **'Start'** as shown below, then click **'Next'**.

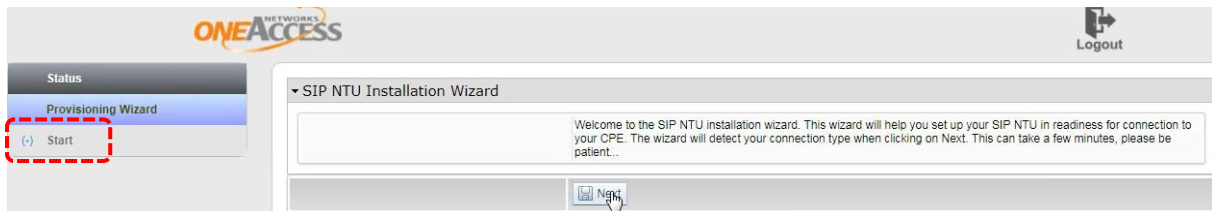

Figure 7: Starting the provisioning wizard

The provisioning wizard presents a checkbox that, when checked, presents fields to enter a static IP address if there is no DHCP server.

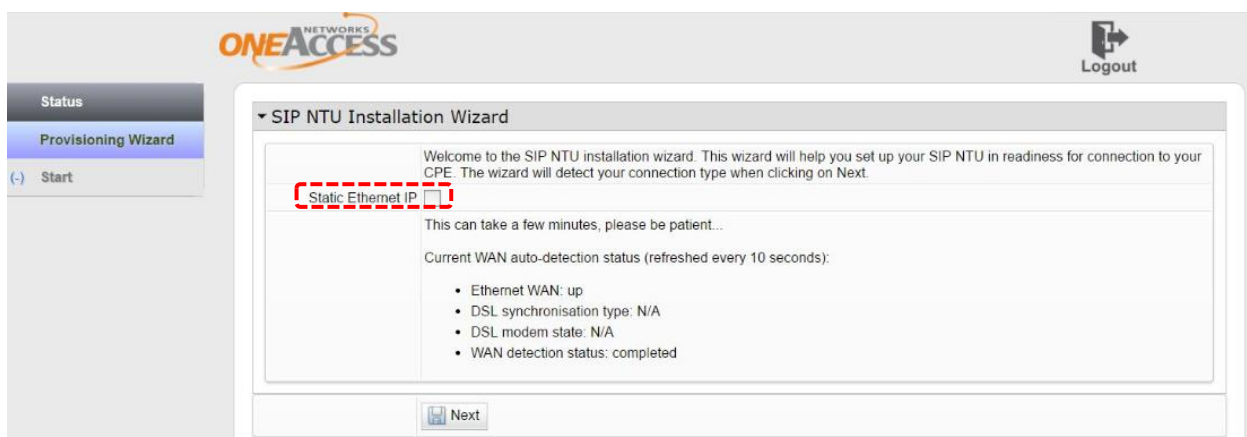

Figure 8: Static Ethernet IP option

Once the Static Ethernet IP checkbox is ticked, the fields will appear as shown in the example below.

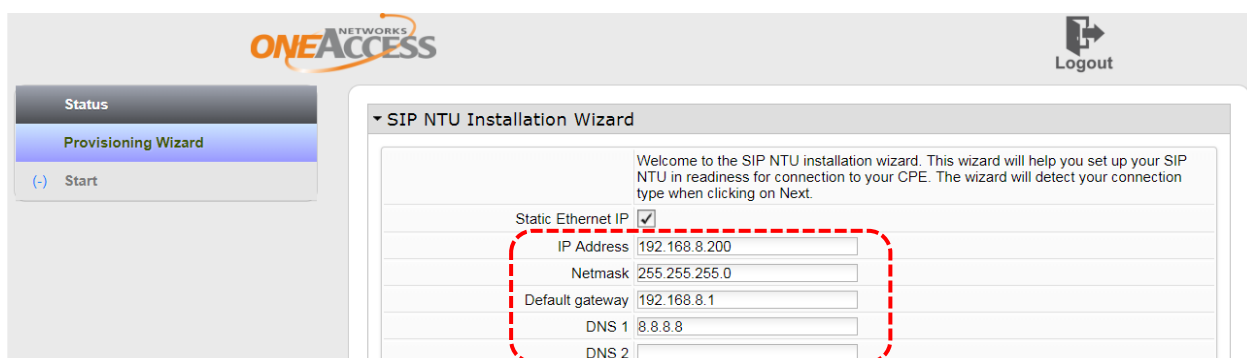

Figure 9: Static Ethernet IP fields

The wizard also presents the current WAN status which is (as indicated in the GUI) refreshed every 10 seconds. The WAN auto-detection feature presents the applicable access types that relate to the particular device (For example Ethernet, ADSL, or VDSL.) In the case of the 425 4B, it will display Ethernet, as shown in the screenshot below.

Once the WAN detection has been completed, click **'Next'**.



Figure 10: Ethernet WAN detected

When the WAN access status is confirmed, you'll see the following screen:

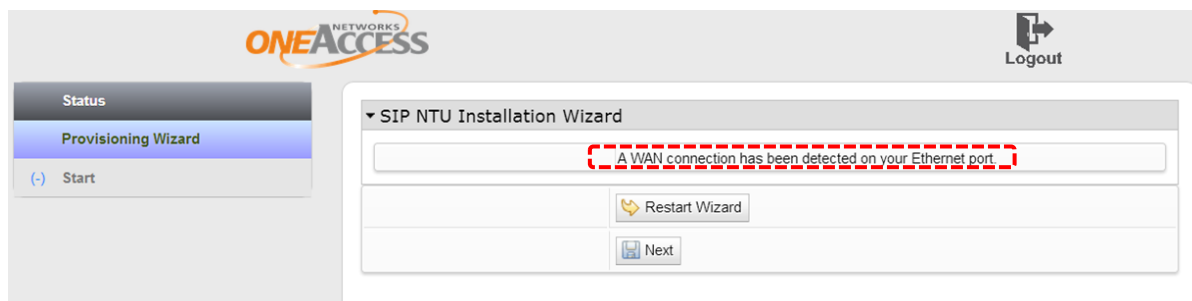

Figure 11: Ethernet WAN confirmed

Note: If you experience any issues you can try another WAN source and re-run the auto detect procedure by selecting **'Restart Wizard'**.

If the WAN connection has been detected, select **'Next'** which presents the fields requesting the Business SIP Platform device ID and password.

5.1.4. SIP NTU registration to the Business SIP Platform

The SIP NTU must to be registered to the Business SIP Platform to complete the SIP NTU configuration. You will need to use the 12 digit device ID and 16 digit password (also referred to as “device credentials”) which are available from the Business SIP Customer Management Portal (<https://portal.mycalling.telstra.com>). Refer to section **8.2 Appendix - Retrieving NTU Device ID and password**.

To register the SIP NTU to the Business SIP Platform, enter the device ID and password as shown below.

If the device ID and password are not accepted, check that the digits have been entered correctly. Retry this procedure at least three times. If you still can't connect, confirm you're your internet connection is functioning by using a laptop to access the internet before contacting the Telstra support team.

ONEACCESS NETWORKS Logout

SIP NTU Installation Wizard

Establishing northbound connectivity to the core application server:

Please enter the device credentials username and password. You should have previously obtained these from the customer web portal. On the portal navigate to "SIP Trunk" then "SIP NTU" and click on "Get Credentials". Enter the "Username" and "Password" provided into the fields below.

Tick the "Replace Faulty Unit" checkbox for the replacement of a faulty unit that was properly functioning. It will restore the configuration from the previously installed unit. The "Username" and "Password" are still required.

After the completion of this phase, which can take a few minutes, navigate on this GUI to "Status" then "Voice" and confirm that the "Registration state" is shown as Registered. Once done, for new installations, navigate to "Provisioning Wizard" then "PBX Type" to configure the southbound settings for the PBX.

Replace Faulty Unit

Username

Password

Figure 12: Enter Business SIP Platform Device ID and Password

Note: The **Replace Faulty Unit** checkbox is used when installing a new device to replace a faulty one that was fully configured. It downloads the saved configuration for the **original unit** replicating all the existing settings thus reducing the risk of introducing changes.

IMPORTANT: This option is ONLY for replacing the same make/model of SIP NTU. It is not for use when upgrading/downgrading the SIP NTU.

To confirm that the SIP NTU is registered, select **'Voice'** and check for a value of 'Registered' as shown in **Figure 13** below. The SIP NTU is now registered with the Business SIP Platform.

If the GUI screen does not show 'Registered', wait a few minutes and then refresh the status by clicking on 'Reload Statistics'.

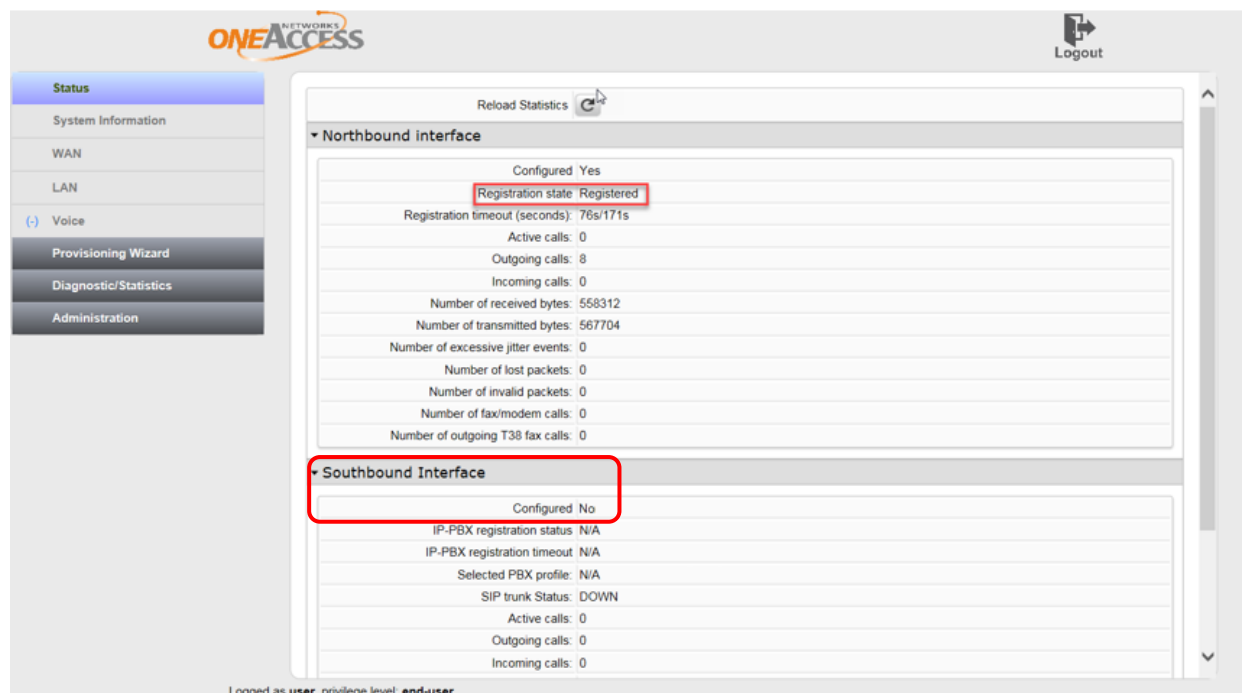

Figure 13: Voice interface registered with the Business SIP Platform

The network-side (Northbound) installation of the SIP NTU and registration with the Telstra Business SIP platform is now complete.

Note: In the figure above, the 'Southbound' Interface' section, refers to the PBX and shows the '**Configured**' field indicating '**No**'. This signifies the starting point for the SIP NTU configuration to the PBX (Southbound).

On successful network-side (Northbound) configuration, the Provisioning Wizard will present the '**PBX Type**' configuration page, shown in the next section.

5.1.5. Verification of the network-side (Northbound) configuration

Before proceeding to the PBX-side (Southbound) configuration, refer to the **'Status'** screen to verify that the network-side (Northbound) configuration is complete and check the **'PBX Configured'** status as shown below:

Notice that the **'PBX Configured'** field shows **'No'**.

The screenshot shows the ONEACCESS NETWORKS Status screen. On the left is a navigation menu with 'Status' selected. The main content area is divided into two sections: 'System Information' and 'System Status'. The 'System Status' section contains a table with the following data:

System Status	
Device up-time	0d 1h 5m 4s
Device start cause	Software requested
WAN Auto-Detection	Completed (Ethernet)
Update from Provisioning Server	Done
PBX Configured	No

Figure 14: Confirming SIP NTU network-side (Northbound) configuration

6 SIP NTU to PBX-side configuration (Southbound)

This section covers the following activities to complete the SIP NTU to PBX (Southbound) configuration:

1. Pre configuration considerations
2. Logging in to the SIP NTU GUI via the web browser interface (requiring a username and password)
3. Verifying the Northbound configuration
4. Selecting the PBX Type
5. Configuring ISDN BRA/BRI PBX services
6. Configuring ISDN PRA/PRI PBX services
7. Configuring IP PBX services
8. SIP NTU configuration status verifications
9. Making test calls from the SIP NTU to the Business SIP Platform.

6.1. Pre-PBX-side configuration considerations

Before configuring the SIP NTU to the PBX the following is recommended reading to ensure an understanding of what may be involved in this stage:

- Existing BRA/BRI port connections should be labelled so that the cables can be correctly connected to the new SIP NTU.
- Confirm if DID/Multi Number is applicable and familiarise yourself with section **6.5.4 DID/Multi-number**.
- Verify that the network-side configuration of the SIP NTU has been completed by login into the SIP NTU GUI and checking the Status page.
See **Figure 16: Initial status screen confirming SIP NTU provisioning**
- Prepare your plan for moving any cabling from an existing PBX as there will be service disruption. Where the Business SIP product is replacing existing ISDN services a Number Migration activity will be required and this needs to be coordinated with cable moves between an existing NT1 device and the new SIP NTU. To rollback both number migration and cabling may be required and these should be performed with care. For more details about number migration see section **7 Number migration**.

6.2. SIP NTU login

Connect your laptop to Ethernet port 0/2 or 0/3 on the SIP NTU, open a web browser and enter **192.168.9.1** to open the login page.

The customer or their technical contact should have the username and password, which would have been 'force-changed' on initial installation.

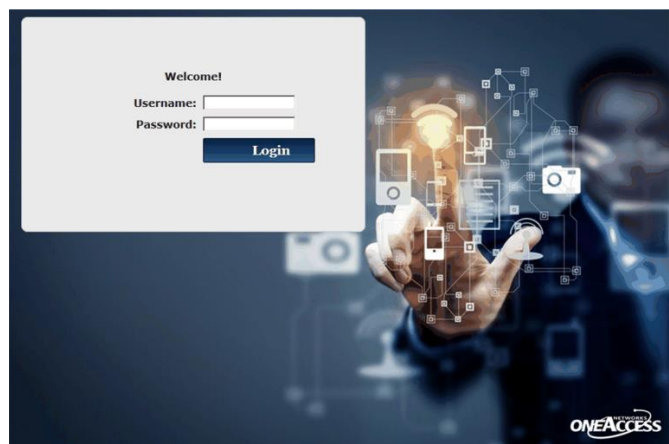

Figure 15: SIP NTU login page

For password related issues contact Telstra on [\(1800 790 831\)](tel:1800790831).

6.3. Confirm SIP NTU network-side (Northbound) status

Before starting, confirm that the provisioning has been completed by checking the status screen as shown below:

Notice that the **'PBX Configured'** field shows **'No'**.

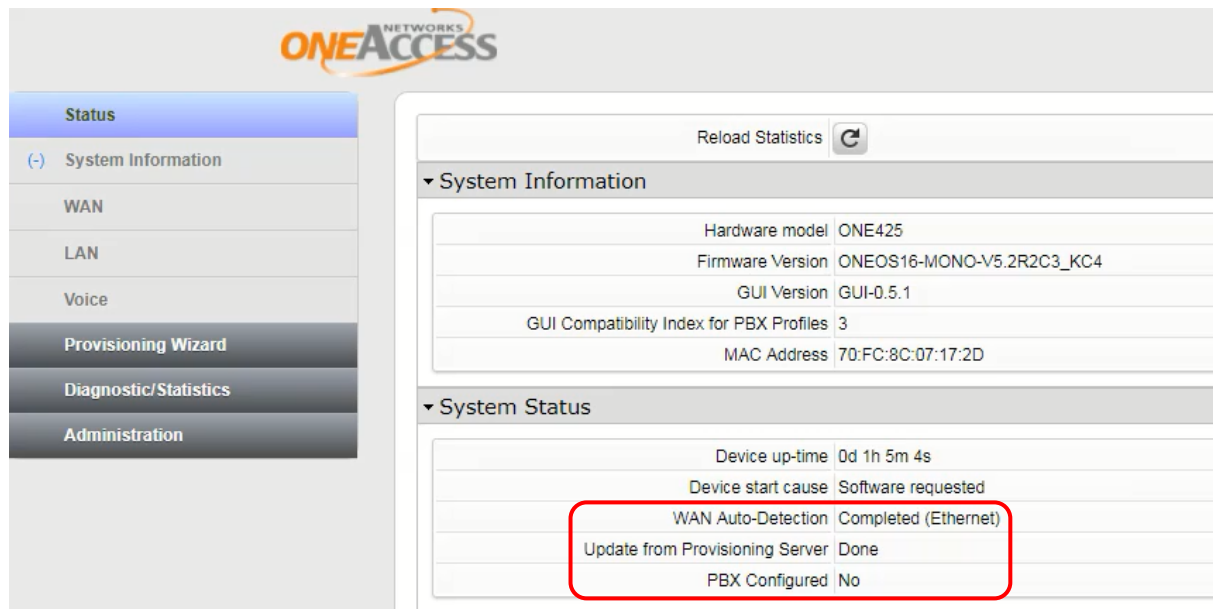

Figure 16: Initial status screen confirming SIP NTU provisioning

To start the Southbound configuration, in the left navigation pane, select the **'Provisioning Wizard'** and click **'PBX Type'** as shown below.

6.4. Selecting the 'PBX Type'

Before commencing this activity, confirm the PBX type to be configured to determine the relevant section below.

The **'Provisioning Wizard'** will present two **'PBX Type'** options:

- Ethernet (SIP PBX)
- ISDN

Select the applicable option and click the **'Save'** button.

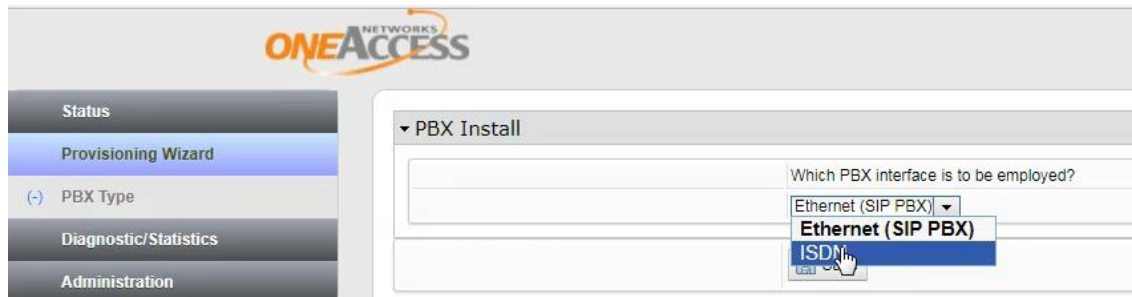

Figure 17: SIP PBX Selection

Click **'Save'** and the page will refresh and return to the **'Status'** screen displaying the selected PBX type, as shown below in the example below:

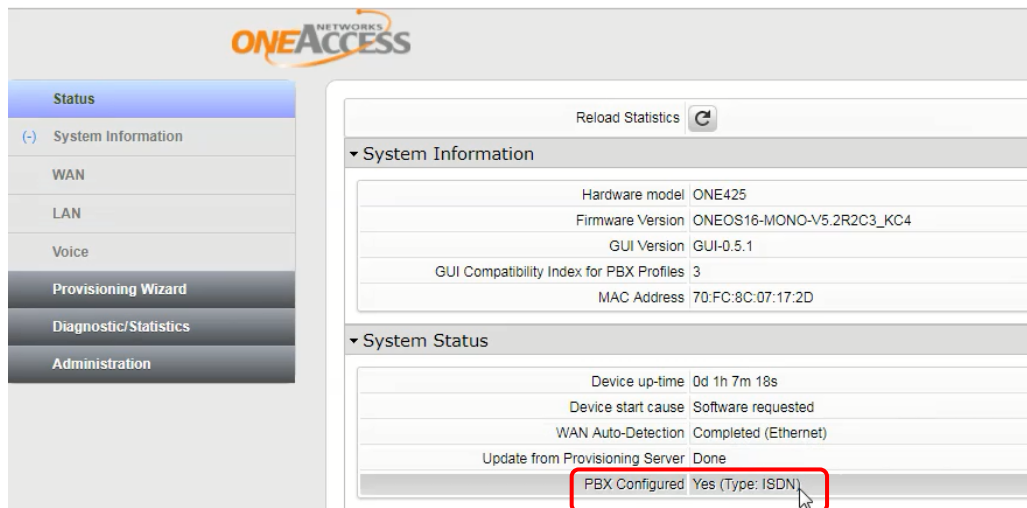

Figure 18: PBX status screen confirming PBX type selected

Refer to the applicable section for the specific PBX type.

- **'ISDN'** (Refer to section 6.5 for BRA/BRI or 6.6 for PRA/PRI configurations.)
- **'Ethernet SIP'** (Refer to section 6.7 for IP PBX configuration)

6.5. SIP NTU to ISDN BRA/BRI PBX

Once **ISDN** is selected, the wizard automatically detects the BRA/BRI interfaces and the GUI presents the appropriate screen.

Important: To migrate to the new Telstra Business SIP service, disconnection and cutover is required (not applicable to brand new services, i.e. not migrating from an existing PBX) which creates a service interruption. This is required during the SIP NTU to PBX (Southbound) configuration.

6.5.1. ISDN BRA/BRI configuration (Example One425)

The GUI detects the ISDN ports on the SIP NTU and when the **‘Provisioning Wizard’** option is selected in the left navigation pane, the available BRI ports are presented. In the example below these are 5/0 to 5/3. As each BRA/BRI port is selected, it is flagged with a blue marker indicating that it is ready for configuration and the corresponding fields appear in the right window, as indicated by the red boxes in the image below.

Note: There is no preferred order to configure the ports but is strongly recommended that **all ports** be **‘Enabled’** by selecting each one in turn from the left menu (e.g. BRI 5/0 shown below, BRI 5/1, BRI 5/2, BRI 5/3) and ticking the **‘Enabled’** check box as shown below; **even if not all are used/connected**.

The recommended settings should be used unless other specific settings are required.

Select **‘Save’** to apply the port configuration to the SIP NTU. Configure each BRA/BRI port in the same way; using the recommended settings as shown in the table, further below, unless the customer PBX requires specific settings.

The two configuration groups presented are: **Physical Port Settings** and **ISDN Settings**; although another configuration for BRA/BRI is **“DID/Multi-Number”**, detailed further below.

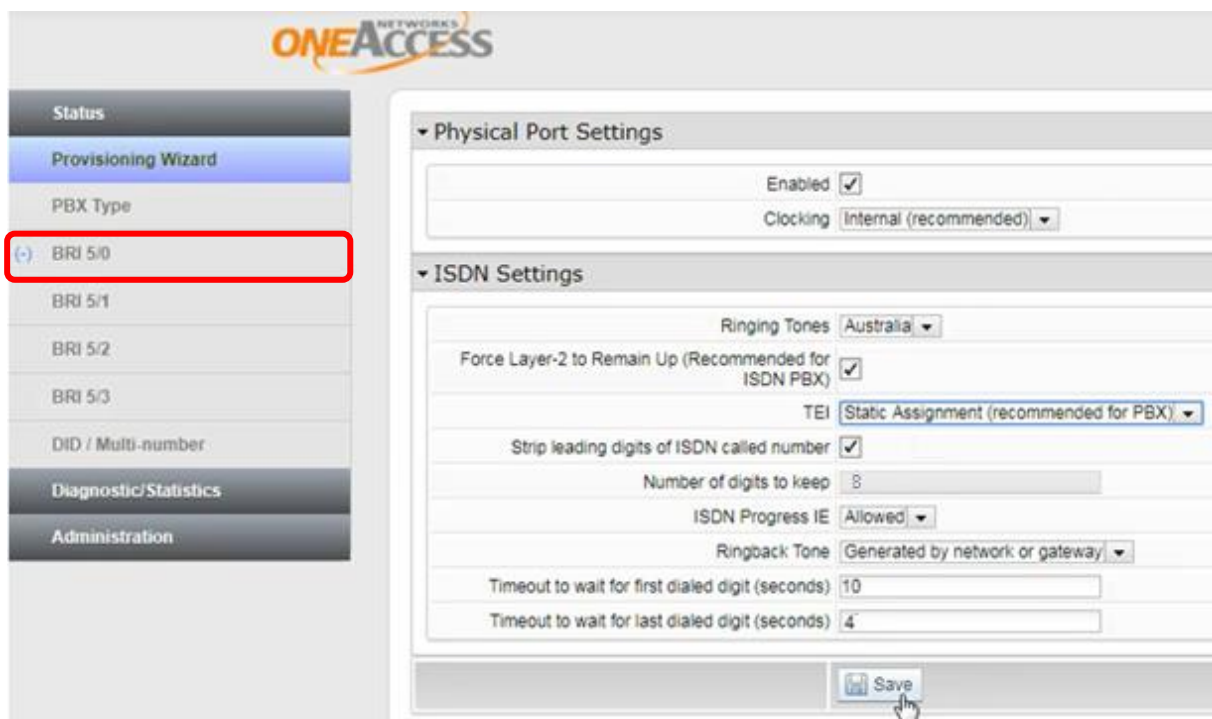

Figure 19: BRA/BRI port selection

6.5.2. BRA/BRI ‘Physical Port Settings’

The recommendation is for **all ports** for BRA/BRI services be set to **‘Enabled’** by the technician (default) and the clocking set to **‘Internal’**, as shown in the example above.

Field	Recommended Setting
Enabled	Tick this box to enable the interface (default)
Clocking	Use this to specify the clocking mode; by default, Internal is recommended.

Table 1: Recommended BRA/BRI Physical Port Settings

6.5.3. BRA/BRI ‘ISDN Settings’

The following are the recommended ISDN settings for BRA/BRI; although some PBXs may require different settings in some circumstances.

For example: Most PBXs require the TEI setting “Static Assignment”, although some PBXs may need to use the “Negotiated” setting, where the PBX test calls fail and/or the ‘ISDN layer 2’ value, in the ISDN Status Verification, shows **‘Down’**. See section 6.8.1 ISDN PBX status verifications.

Field	Recommended setting
Ringing tones	Australia
Force layer 2 to Remain Up (Recommended for ISDN PBX)	Ticked
TEI	The normal recommended setting is “Static Assignment”, however some PBXs need the “Negotiated” option, even though it is for ISDN phones.
Strip leading digits of ISDN called number	Ticked
Number of digits to keep	8
ISDN progress IE	Allowed
Ring back tone	Generated by network or gateway
Timeout to wait for first dialled digit (seconds)	10 (secs)
Timeout to wait for last dialled digit (seconds)	4 (secs)

Table 2: Recommended BRA/BRI ISDN Settings

During this part of the configuration process, the service numbers aren’t yet assigned to the ports on the new SIP NTU. When you have configured all the BRA/BRI ports, select the **DID/Multi-number** option to assign the service numbers.

6.5.4. DID/Multi-number

Telstra recommends that the Multi-number option be left unchecked (with numbers left unassigned) as it will not be applicable to the vast majority of PBXs.

Configure the NTU as 'DID' (leave Multi-number UNCHECKED) and refer to this page only where there is a requirement specific to your installation.

The three options are described below:

1. **DID (Direct in Dial)** (default) – a range of numbers, which can't be assigned to individual ports.
Note: This is the most flexible configuration and allows any available numbers to be used on any port, effectively pooling the numbers. Incoming hunting will occur across any of the spare channels on any connected BRI in this configuration, irrespective of the numbers dialed and numbers do not need to be in a continuous block.
2. **Multi-number** – if it is a requirement to assign Primary/Auxiliary numbers to specific BRA/BRI port(s) then this can be achieved through this option.
3. **Line Hunt Multi-number** – if it is a requirement to configure a Line Hunt across particular numbers on specific PBX ports this can be achieved through this option.

Assigning numbers to physical ports (only applicable to options 2 and 3 above)

A range of numbers downloaded by the SIP NTU as part of the DMS update procedure, initially appear as '**Unassigned Numbers**', as shown below. Selecting the '**Multi-number**' option in the '**Provisioning Wizard**' enables these numbers to be assigned to the '**Port #n**' fields using a drag & drop method. The screenshot below demonstrates how to assign phone numbers to the physical ISDN ports.

To retain the alignment with the PBX settings, the numbers must be assigned to the same ports as they were on the existing ISDN NT1.

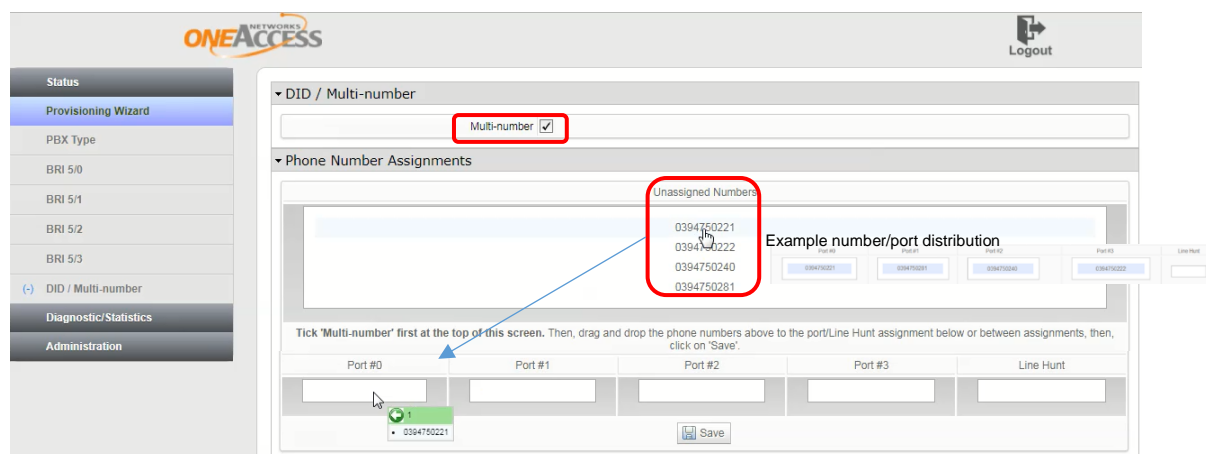

Figure 20: Assigning numbers

Phone calls to any numbers configured against BRA/BRI ports 0-3 will only be offered to their specific ports (= ISDN Basic Rate Multiple Number). Not selecting and configuring Multi-number will ensure that all calls are distributed across all active (used) ports.

Any numbers assigned to the line hunt field will hunt across all active ports.

To replicate the ISDN Line Hunt/Multiple Number product, assign the Group Directory Number (GDN) to the **Line Hunt** field.

6.6. SIP NTU to ISDN PRA/PRI PBX

Once **ISDN** is selected, the wizard automatically detects the PRA/PRI interfaces and goes to the appropriate screen.

Important: To migrate to the new Telstra Business SIP service, disconnection and cutover is required (not applicable to brand new services, i.e. not migrating from an existing PBX) which creates a service interruption. This is only required once the SIP NTU to PBX (Southbound) configuration has been completed and verified in the SIP NTU GUI.

6.6.1. ISDN PRA/PRI configuration

There may be a single or multiple PRA/PRI ports on a given device, however the configurations are the same in both cases.

The GUI detects the ISDN ports on the SIP NTU and when the 'Provisioning Wizard' option is selected in the left navigation pane, the available PRA/PRI port(s) is/are presented.

There are three configuration groups presented with PRA/PRI ISDN services: **'Physical Port Settings'**, **'ISDN Settings'** and **'Timeslot Allocation'** as shown in the following screenshot and the settings for these are detailed in tables further below.

The recommended settings should be used unless other specific settings are required and each PRA/PRI port must be configured the same.

Select 'Save' to apply the port configuration to the SIP NTU.

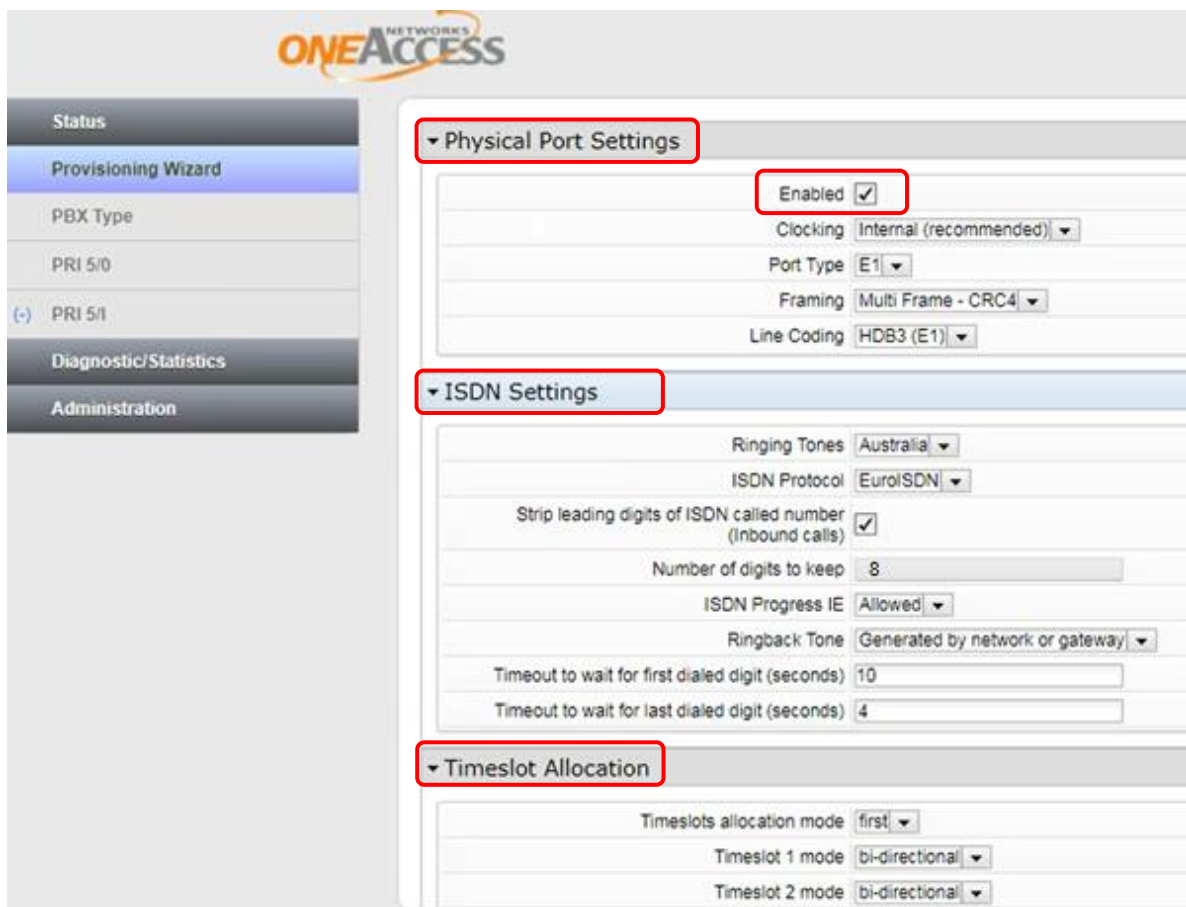

Figure 21: PRA/PRI configuration groups

6.6.2. PRA/PRI 'Physical Port Settings'

The recommendation is for **all ports** for PRA/PRI services be set to **'Enabled'** by the technician (default) and the clocking set to **'Internal'**, as shown in the example above.

Note: Some SIP NTU models have the default set to Double Frame and so it is recommended to always check this setting.

Field	Recommended Setting
Enabled	Tick this box to enable the interface (default)
Clocking	Use this to specify the clocking mode; by default, Internal is recommended.
Port Type	E1
Framing	Multi Frame – CRC4
Line Coding	HDB3 (E1)

Table 3: Recommended PRA/PRI Physical Port settings

6.6.3. PRA/PRI 'ISDN Settings'

The recommendation is for **all ports** for PRA/PRI services be set to **'Enabled'** by the technician (default) and the clocking set to **'Internal'**, as shown in the example above.

The following are the recommended ISDN settings for PRA/PRI:

Field	Recommended setting
Ringing tones	Australia
ISDN Protocol	EuroISDN
Strip leading digits of ISDN called number	Ticked
Number of digits to keep	8
ISDN progress IE	Allowed
Ring back tone	Generated by network or gateway
Timeout to wait for first dialled digit (seconds)	10 (secs)
Timeout to wait for last dialled digit (seconds)	4 (secs)

Table 4: Recommended PRA/PRI 'ISDN Settings'

6.6.4. PRA/PRI ‘Timeslot Allocation’

On the PRA/PRI SIP NTUs you can configure up to 31 timeslots per PRA/PRI interface with incoming and outgoing calls:

Select **Timeslots allocation mode** as “first” as a default. This means that incoming calls are offered the lowest free timeslot first. This should be changed only when frequent call collisions occur with PBX outgoings calls and the PBX selection can’t be changed.

Bi-directional means that the particular timeslot can be used for either incoming or outgoing calls.

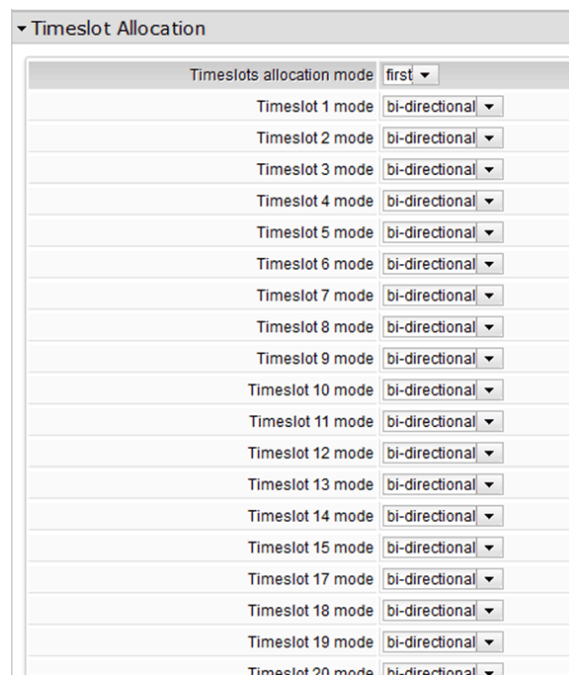

Figure 22: Recommended PRA/PRI Timeslot Allocation settings

Click on the ‘**Save**’ button to send the configuration to the OneAccess SIP NTU:

6.6.5. ISDN PBX configuration completion

After successfully configuring the ISDN BRA/BRI or PRA/PRI PBX, the following screen should appear with the provisioning wizard confirming the status of the PBX as indicated below:

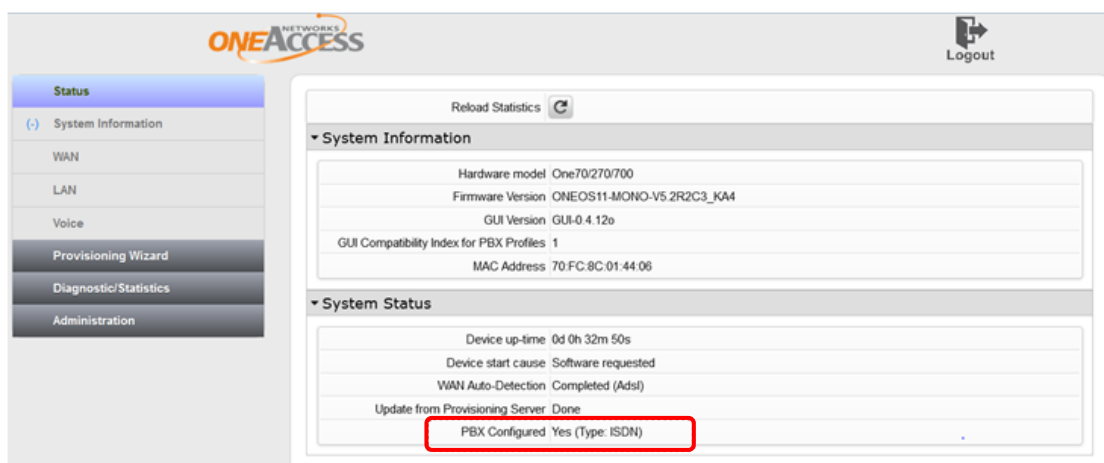

Figure 23: ISDN PBX configuration confirmation

6.7. SIP NTU to IP PBX

On successful network-side (Northbound) configuration, the Provisioning Wizard will present the ‘**PBX Type**’ configuration page, shown below.

Before commencing this activity, confirm that the PBX type to be configured is a SIP PBX, otherwise refer to section 6.5 for BRA/BRI or 6.6 for PRA/PRI configurations.

The dropdown highlighted below will present two options:

- ISDN
- Ethernet SIP

Select the applicable option (for IP PBX select ‘**Ethernet (SIP PBX)**’) and click the **Save** button.



Figure 24: SIP PBX Selection

6.7.1. SIP PBX Configuration

When selecting a SIP PBX you will be redirected to the **SIP PBX Configuration** pages as below.

Note: IP PBXs used with Business SIP must be accredited for use and specific configuration and troubleshooting documentation provided by their respective vendors.

▼ Main IPPBX Settings

PBX profile	Panasonic KX-NS700AL
Model	KX-NSX1000BX
Version	Version 2
Firmware	2.22007
User Agent	Panasonic-MPR18-V002.22007/VSIPGW-V3.000
Setting Loaded	Device
IPPBX Status	Registered

▼ Main Settings

Display Advanced Settings

Topology: NTU Attached ▼

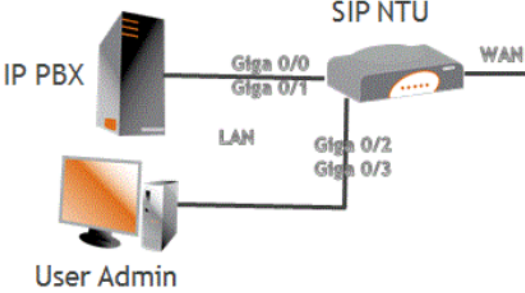

For this networking topology,

- The SIP NTU learns its IP address from a remote DHCP Server from the LAN network, OR
- The SIP NTU is assigned with a static IP address on the LAN network.

The Voice Southbound LAN is available on the ports GigabitEthernet 0/0 to GigabitEthernet 0/1. The IP address is 192.168.109.1. However the DHCP server is enabled on the SIP NTU to allow user connection on GigabitEthernet 0/2 to GigabitEthernet 0/3. Please disconnect and re-connect the end-user tool if an IP address is not assigned. The callsig-port for the link between SIP NTU and IP PBX is configurable (preferred 5062). Outbound-proxy of PBX shall be updated. However the DHCP server is enabled on the SIP NTU to allow user connection on GigabitEthernet 0/2 to GigabitEthernet 0/3. Please disconnect and re-connect the end-user tool if an IP address is not assigned.

Voice LAN – DHCP Client	<input type="checkbox"/>
Voice LAN IP Address	192.168.109.1
Voice LAN IP Mask	255.255.255.0
Register PBX?	<input checked="" type="checkbox"/>
PBX IP Address	192.168.109.50
PBX Address Of Record (AOR)	285759400
Authenticate PBX?	<input checked="" type="checkbox"/>
Username	285759400
Password	••••

Figure 25: SIP PBX Configuration Page

Tick the **Display Advanced Settings** checkbox to display the following fields:

Advanced Settings

▼ Encryption / Transport	
SIP Transport Protocol	UDP
Signaling Port	5062
PBX TCP/UDP Listening Port	5060
▼ PBX Monitoring	
SIP Ping	Disabled
▼ Caller Presentation	
Include P-Asserted-Id	<input type="checkbox"/>
Include P-Preferred-Id	<input type="checkbox"/>
Always include Privacy	<input type="checkbox"/>
Privacy Format	Privacy: user, id
Connected Party Presentation	P-Preferred-Id
Number Processing	None
National Number Format	Unchanged
▼ Other Signalling Interoperability Parameters	
User Agent Detection	^.{0,126}\$
User Agent Detection Timeout	
DTMF Transport	In-band (RFC4733)
DTMF Payload Type	101
SIP Session Timers	Disabled
Send '200 OK' Upon BYE	When call is released by remote
Include Call Redirection Information in	SIP Diversion header
Send PRACK	Disabled
Always Include UDP Port in 'Via' header	<input type="checkbox"/>
▼ Codecs	
Enable G.711A	Priority 1, 20 ms play time
Enable G.711 µ	Priority 2, 20 ms play time
Enable G.722r48	Disabled
Enable G.722r56	Disabled
Enable G.722r64	Disabled
Enable G.722.2	Disabled
Enable G.729	Priority 3, 20 ms play time
Enable Clear Channel	Priority 8, 20 ms play time
▼ SDP Parameters	
Handle SDP in '180/183'	Always
SDP Format to Put Media on Hold	a=send-only and 0.0.0.0
Include SDP offer only first INVITE	<input type="checkbox"/>
Codec Selection Priority	Use remote codec priority list (recommended)
SDP Answer	Include complete local codec list (recommended)

Figure 26: SIP PBX Advanced Settings Configuration Page

Continue to the 'PBX Profile' section below.

6.7.2. PBX Profile

In this menu, user selects SIP PBX type from the **'PBX' profile** drop box. The list of profiles contains only certified IP PBX types. If the PBX does not appear in the drop down list then you may not be able to get the IP PBX operational.

To continue select applicable PBX from the menu and go to **'Topology'** section below.

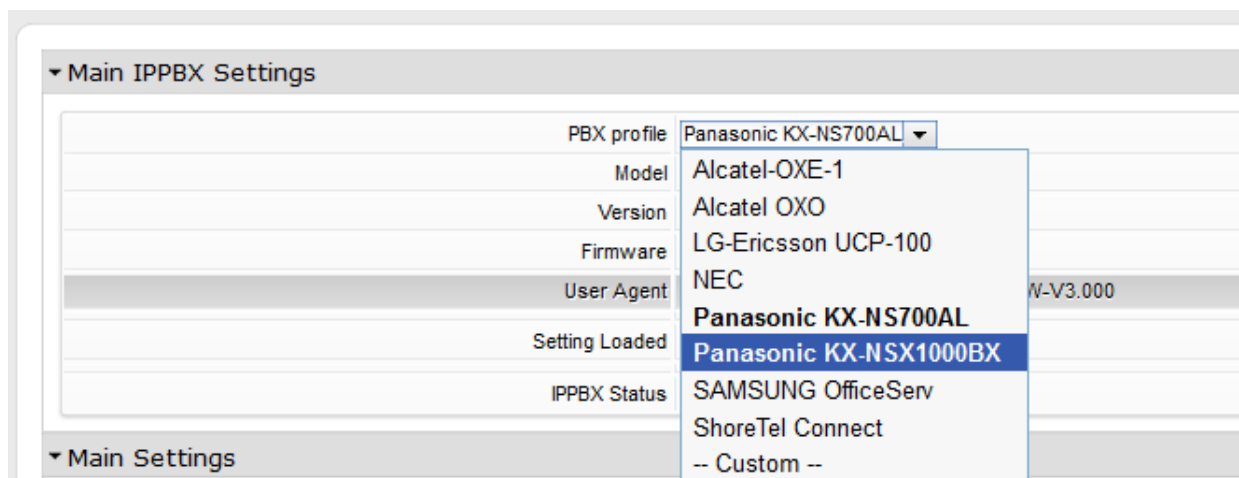

Figure 27: SIP PBX Profile Selection

6.7.3. IP PBX Topology and configuration

There are two types of topologies within which a SIP PBX can be installed:

1. NTU Attached
2. Gateway Attached

NTU Attached

In this topology the SIP PBX is connected directly to the one of the LAN ports of the OneAccess SIP NTU as shown below:

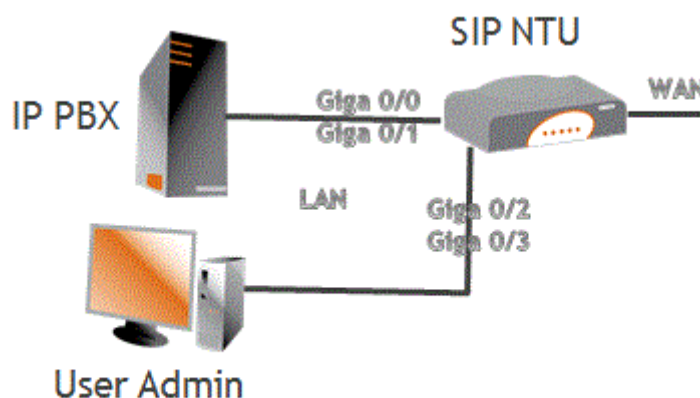

Figure 28: IP PBX Attached to SIP NTU Topology

The following table presents the steps to configure for SIP NTU Attached. Refer to the ‘Main Settings’ section in the screenshot below the table:

Step	Action
1	In the ‘Main Settings’ section, tick the Register PBX checkbox
2	Enter the IP address in the range 192.168.9.0/24 e.g. 192.168.9.50 into the ‘ PBX IP Address ’ field
3	Enter Mac address of the SIP PBX (see PBX manufacture technical specifications) in the ‘ PBX MAC Address ’ field
4	Enter the pilot number in ‘ PBX Address of Record (AoR) ’ field e.g. 0395577721
5	Tick the Authenticate PBX checkbox
6	Enter the username and password to match IP PBX authentication; Username: Trunk ID (e.g. st6185351358) ; Password user defined (e.g. AriaPBX)
7	Click on Save button

Figure 29: Steps to configure PBX Attached to SIP NTU Topology

The screenshot displays the configuration interface for a SIP NTU. It is divided into two main sections: 'Main IPPBX Settings' and 'Main Settings'.

Main IPPBX Settings:

- PBX profile: Panasonic KX-NS700AL
- Model: KX-NSX1000BX
- Version: Version 2
- Firmware: 2.22007
- User Agent: Panasonic-MPR18-V002.22007/VSIPGW-V3.000
- Setting Loaded: Device
- IPPBX Status: Registered

Main Settings:

- Display Advanced Settings:
- Topology: NTU Attached

A network diagram shows an IP PBX connected to a SIP NTU. The IP PBX is connected to the SIP NTU via GigabitEthernet 0/0 and 0/1. The SIP NTU is connected to a User Admin PC via GigabitEthernet 0/2 and 0/3. The SIP NTU also has a WAN port.

For this networking topology, the following instructions are provided:

- The SIP NTU learns its IP address from a remote DHCP Server from the LAN network, OR
- The SIP NTU is assigned with a static IP address on the LAN network.

The Voice Southbound LAN is available on the ports GigabitEthernet 0/0 to GigabitEthernet 0/1. The IP address is 192.168.109.1. However the DHCP server is enabled on the SIP NTU to allow user connection on GigabitEthernet 0/2 to GigabitEthernet 0/3. Please disconnect and re-connect the end-user tool if an IP address is not assigned. The callsig-port for the link between SIP NTU and IP PBX is configurable (preferred 5062). Outbound-proxy of PBX shall be updated. However the DHCP server is enabled on the SIP NTU to allow user connection on GigabitEthernet 0/2 to GigabitEthernet 0/3. Please disconnect and re-connect the end-user tool if an IP address is not assigned.

Configuration fields:

- Voice LAN – DHCP Client:
- Voice LAN IP Address: 192.168.109.1
- Voice LAN IP Mask: 255.255.255.0
- Register PBX?:
- PBX IP Address: 192.168.109.50
- PBX Address Of Record (AOR): 285759400
- Authenticate PBX?:
- Username: 285759400
- Password: ••••

A 'Save' button is located at the bottom of the configuration area.

Figure 30: IP PBX - NTU Attached Settings

Gateway Attached

In this topology the SIP PBX is connected to the gateway LAN port.

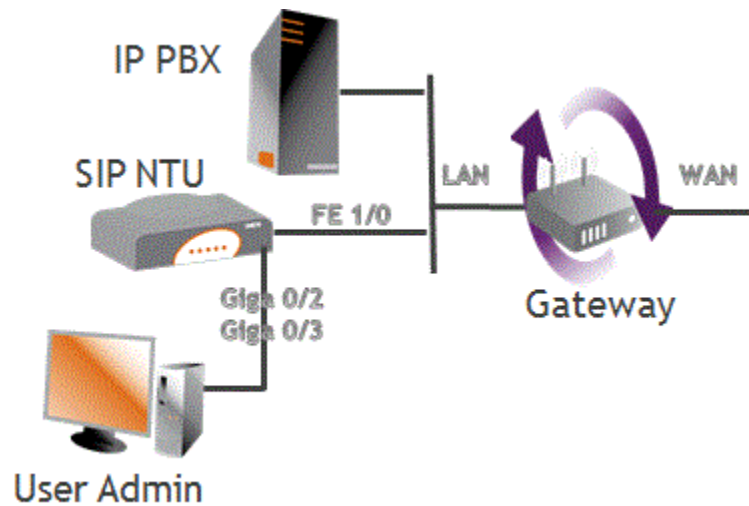

Figure 31: IP PBX Attached to Gateway Topology

The following table presents the steps to configure for Gateway Attached. Refer to the ‘Main Settings’ section in the screenshot below the table:

Step	Action
1	In the ‘Main Settings’ section, tick the ‘ Register ’ PBX checkbox
2	Enter the IP address in the range 192.168.9.0/24 e.g. 192.168.9.50 into the ‘ PBX IP Address ’ field
3	Enter the pilot number in the ‘ PBX Address of record (AoR) ’ field e.g. 0395577721
4	Tick the Authenticate PBX checkbox
5	Enter the username and password to match the IP PBX authentication: Username <Trunk ID> (e.g. st6185351358) ; Password <user defined> (e.g. AriaPBX123)
6	Click on the ‘ Save ’ button

Figure 32: Steps to configure PBX Attached to Gateway Topology

▼ Main IPPBX Settings

PBX profile	Panasonic KX-NS700AL ▼
Model	KX-NSX1000BX
Version	Version 2
Firmware	2.22007
User Agent	Panasonic-MPR18-V002.22007/VSIPGW-V3.000
Setting Loaded	Device
IPPBX Status	Registered

▼ Main Settings

Display Advanced Settings

Topology Gateway Attached ▼

For this networking topology the NTU and the PBX are connected on the same LAN of a gateway. On the NTU side a unique IP interface is required on the Northbound (GigabitEthernet 1/0) interface for the connections to the Network and to the IP-PBX. The SIP NTU local port for the PBX connection is the port 5062 (default), the PBX should be configured accordingly.

The SIP session to the remote network is done on the local NTU port 5060. As a result the SIP connection with the IP-PBX must be done on a different local port. The SIP NTU local port for the PBX connection is the port 5062 (default), the PBX should be configured accordingly.

The current Northbound IP address of the SIP NTU is N/A.

However the DHCP server is enabled on the SIP NTU to allow user connection on GigabitEthernet 0/2 to GigabitEthernet 0/3. Please disconnect and re-connect the end-user tool if an IP address is not assigned.

Voice LAN IP Address	192.168.109.1
Voice LAN IP Mask	255.255.255.0
Register PBX?	<input checked="" type="checkbox"/>
PBX IP Address	192.168.109.50
PBX Address Of Record (AOR)	285759400
Authenticate PBX?	<input checked="" type="checkbox"/>
Username	285759400
Password	••••

Figure 33: IP PBX - Gateway Attached Settings

Click on the ‘**Save**’ button to send configuration to the OneAccess SIP NTU:

6.8. SIP NTU configuration status verifications

This section describes how to obtain and identify the status of the:

- SIP NTU registration both network-side (Northbound) and PBX-side (Southbound)
- ISDN PBX ports (BRA/BRI or PRA/PRI).
- IP PBX ports.

In all cases, log in to the SIP NTU GUI and select Reload Statistics .

When interpreting the Incoming and Outgoing calls counts you will need to consider on which interface the stats are viewed.

The call stats are viewed from the perspective of the SIP NTU, which means that for an “Outgoing” call (e.g. PBX to SIP NTU to Network) the calls will be viewed as “Incoming” on the Southbound side (coming in to the SIP NTU) and as “Outgoing” on the Northbound side (leaving the SIP NTU).

The Northbound Interface will present calls between the SIP NTU and the telco Network whereas the Southbound interface will present the calls between the SIP NTU and the PBX.

6.8.1. ISDN PBX status verifications

The **Voice** status screen in the following images show the state of each configurable component of the SIP NTU

This screenshot shows:

- the SIP NTU is registered
- the PBX (Southbound) interface is configured

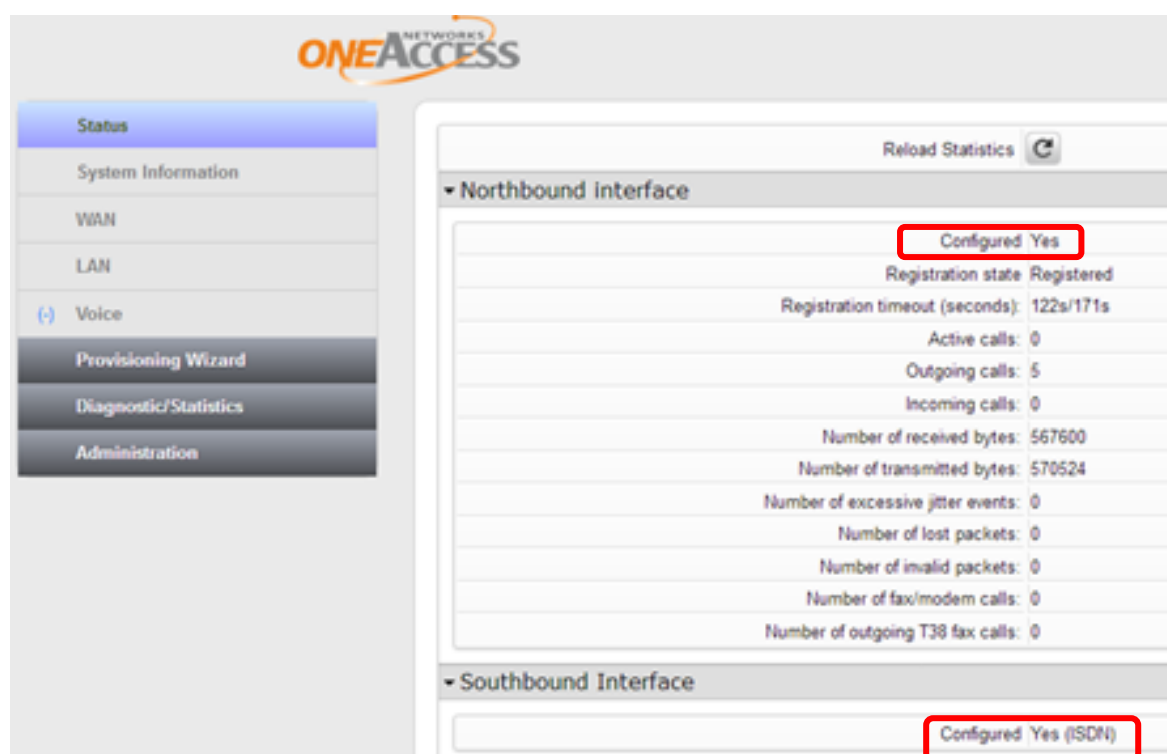

Figure 34: Northbound and Southbound verifications

This screenshot shows the state of the BRI ports (ISDN layer 2 configurations).

IMPORTANT: At this point the PBX MUST be connected to the SIP NTU or Layer 2 will indicate 'DOWN'. It will indicate 'DOWN' if the associated port is unused.

In this example only the first port is in use and the fourth BRI port is omitted:

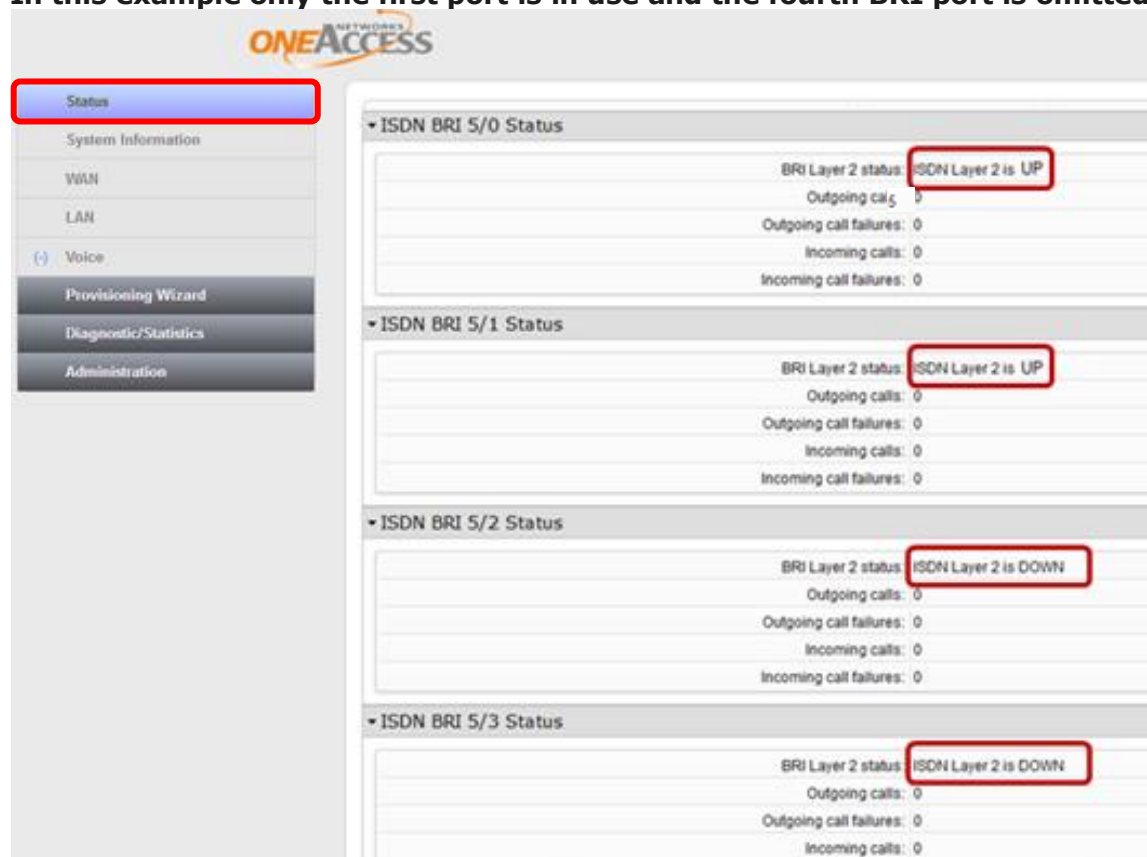

Figure 35: BRI ports verification

This screenshot shows the state of the PRA/PRI ports show the status of both Layers 1 and 2. In this example only 5/0 is in use and working:



Figure 36: PRA/PRI ports verification

6.8.2. IP PBX status verification

The verification for IP PBX configuration is as shown below:

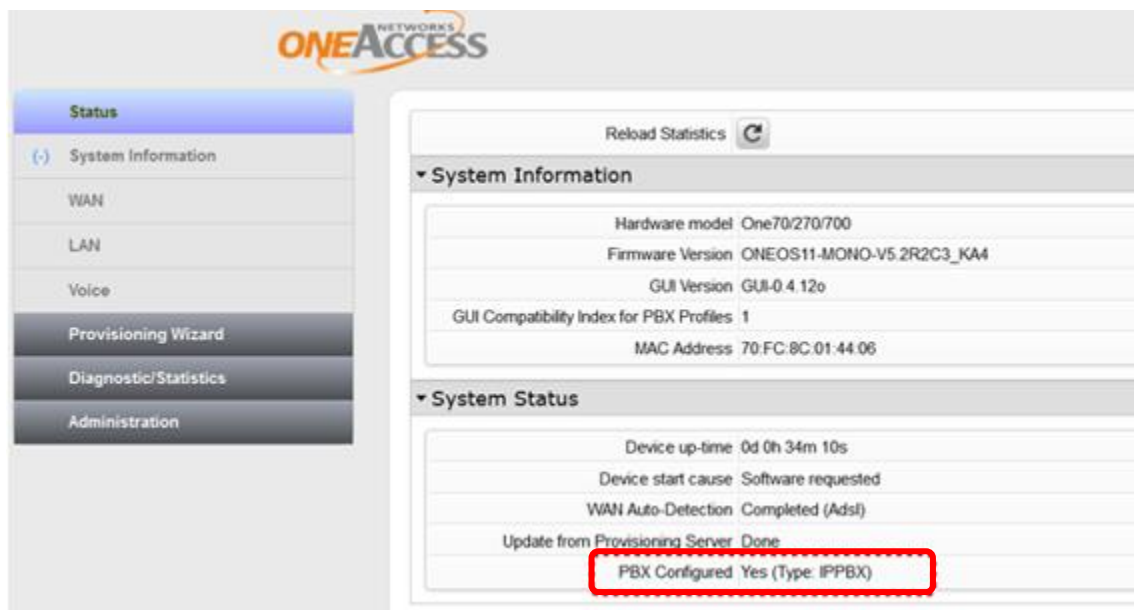

Figure 37: SIP PBX Configuration

6.9. Test Call from SIP NTU

With this feature, a test call can be generated to ensure full operability of the SIP NTU with the Telstra Business SIP Platform. Use **Call Direction** to select the direction of calling – either to the Network (Northbound) or to the PBX (Southbound). The calls can be set to play music (media in only one direction) or provide an audio loopback (media in both directions). Depending on the direction of the call the appropriate called and/or calling number information will be required. In particular, where northbound test calls (to the network) are attempted, you will first need to perform the Outgoing number migration. Refer to section 7.2 Activations (number migration).

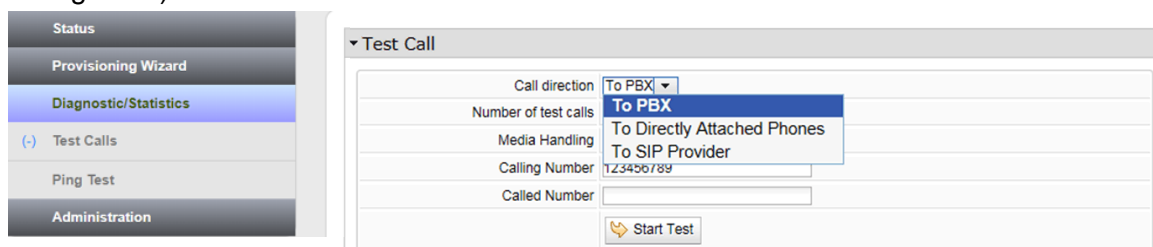

Figure 38: SIP Test Call

6.9.1. Test call instructions

To make a test call, select the **Test Call** option in the navigation menu. Select **Call Direction** to nominate which direction you want the test call to go; **to the SIP Provider (towards the network), to the PBX, or to Directly Attached Phones**.

The following is the sequence to performing a test call:

- Select the **Call Direction** as shown above.
- Set the **Number of test calls** (between 1 and 10).
- Set **Media Handling** to 'Play Music' or 'Loopback Audio'.
- Enter the **Calling Number** (if the pilot number is not defined).
- Enter the **Called Number** (this is the destination number).
- Start the test by clicking the **Start Test** button.

6.9.2. Test Result

The following figure shows an example of test call results:

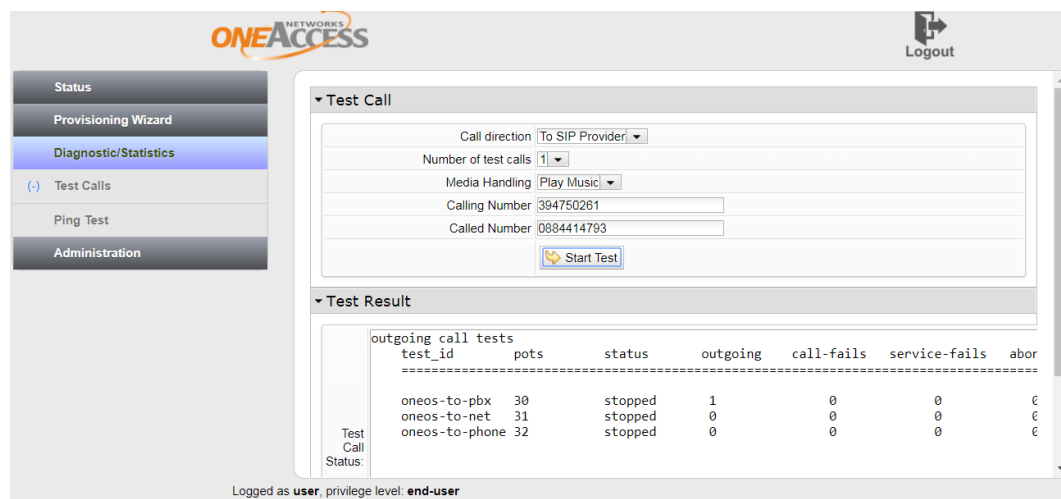

Figure 39: Test Call Results

6.10. SIP NTU Administration

There are basic administration features available and these are described in the screenshots below.

6.10.1. Provisioning Server

Although there is an automated process for updating the device in-line with the server, this can be done manually through this page. Clicking ‘Save’ triggers the automated process that locates and retrieves the file(s) saving them to the device. The update is performed as part of this routine.



Figure 40: Provisioning Server Synchronisation

6.10.2. User Management

This page allows you to create and provide access to other end Users.

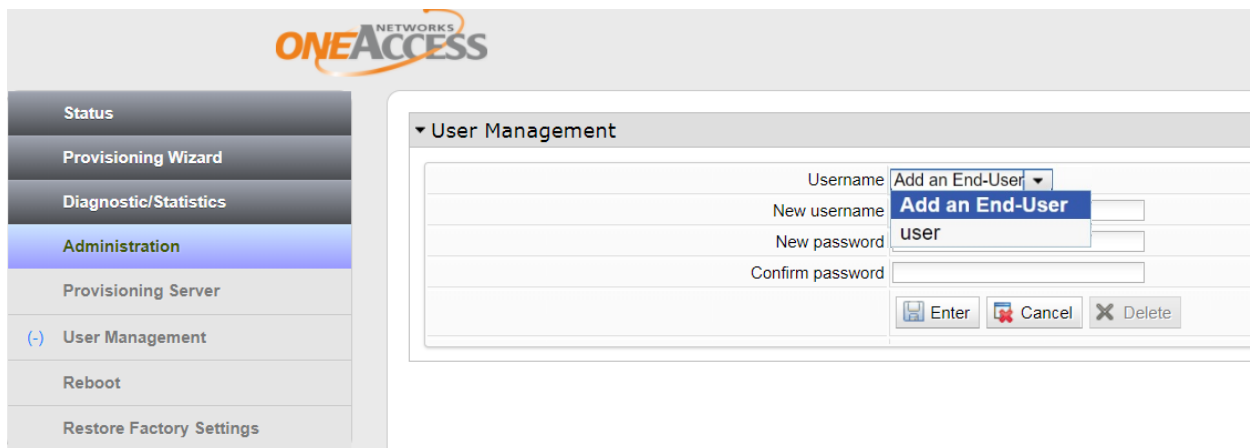

Figure 41: User Management fields

6.10.3. Device Reboot

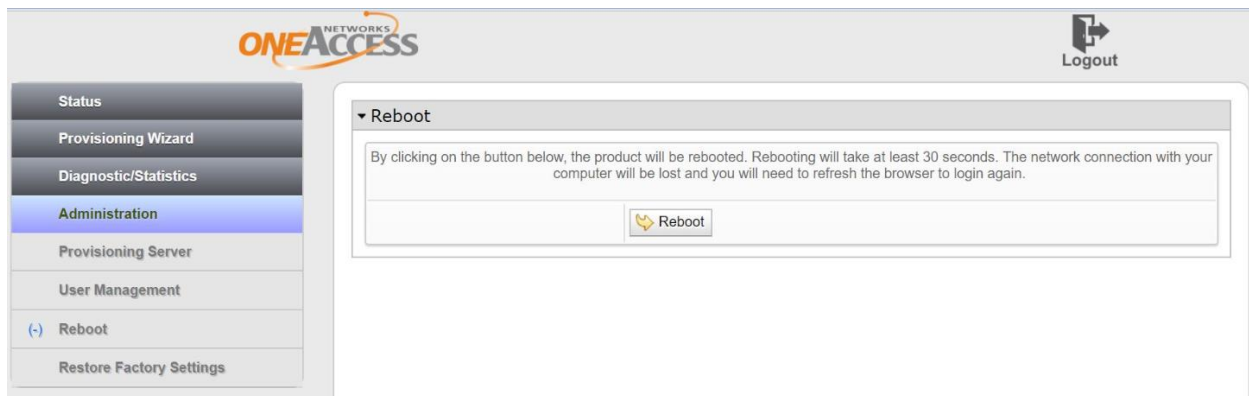

Figure 42: Device Reboot option

6.10.4. Factory Reset

OneAccess NTU’s do not have a factory reset button. Factory Reset functionality is available via the Web GUI. The steps to perform the factory reset are:

1. If not already logged in, open a Web browser and enter **192.168.9.1** to open the Web GUI login page.
2. Enter the Web GUI user ID and password details.
3. From the left side menu, select **Administration** then **Restore Factory Settings**
4. Select the **Restore Now** button, which will present the **‘Are you sure?’** banner.
By selecting **‘OK’**, the default factory configuration will overwrite the current configuration and the device will reboot.

Note: This procedure will require the NTU to be re-registered with the northbound (network side) interface.

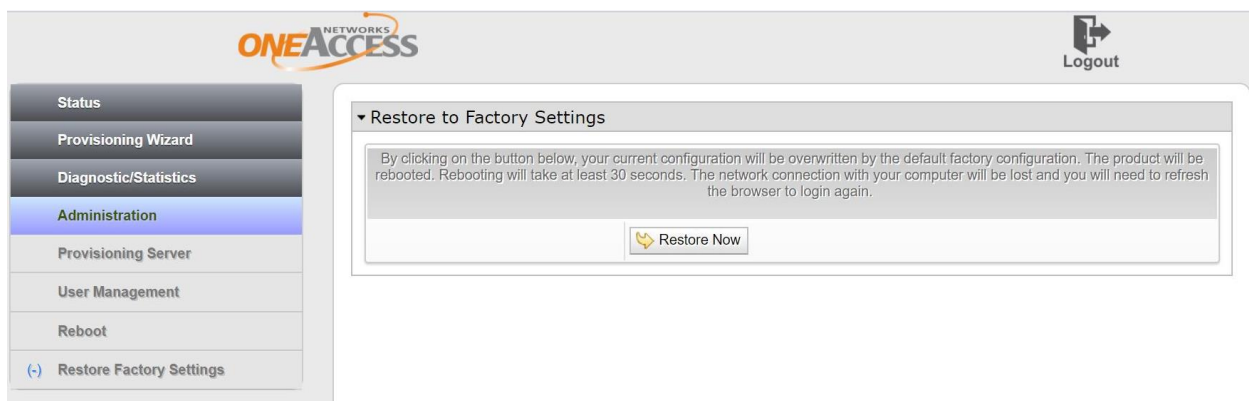

Figure 43: Restore Factory Settings



7 Number migration

Number migration is the final step in establishing a Business SIP service.

IMPORTANT: Only proceed with step if you have completed the SIP NTU to PBX (Southbound) configuration. See step 14 in section 3.2 NTU to PBX-side configuration quick guide.

This section will help you log in to the Business SIP Customer Management Portal to migrate your existing services to Telstra Business SIP. See the Business SIP – Customer Management Portal Administrator login section below for the url and guidelines.

During this process, you will need to perform certain test calls **to** (using a mobile phone or a remote landline) and **from** your service numbers (using your PBX handset) to prove that each stage of the migration has completed successfully before proceeding with the next.

7.1. Business SIP – Customer Management Portal Administrator login

To access the Customer Management Portal, using a laptop, desktop or mobile device with internet access, open a browser and enter <https://portal.mycalling.telstra.com>, which will present the web page shown below.

The Customer Management Portal is designed to be compatible with the following browsers:

- Firefox
- Google Chrome for desktop.

Log in with your username (which begins with 'cu' for Customer admins or 'si' for Site admins) and password; both of which would have been emailed to the business contact prior to the delivery of your equipment.

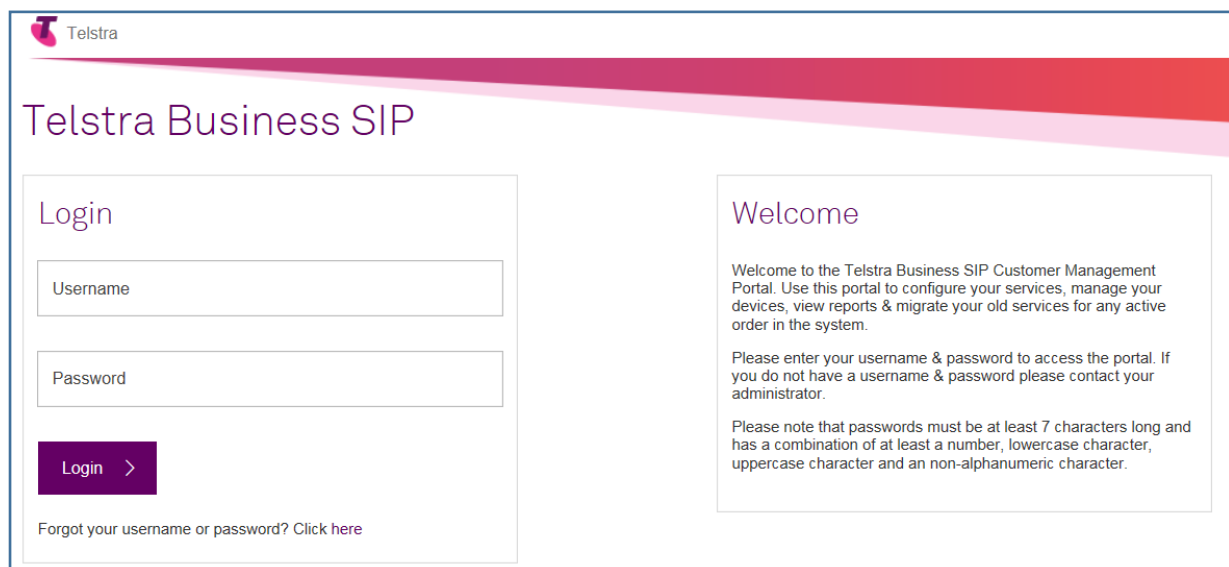

Figure 44: Business SIP Portal Login Screen

Select the Activations tab as shown below, to present the interaction pages.

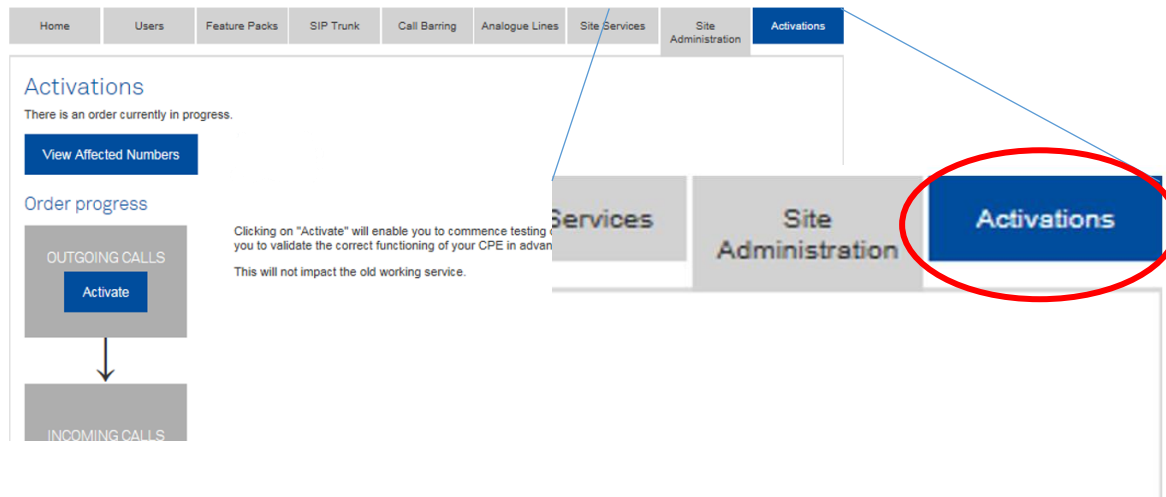

Figure 45: Activations Tab

7.2. Activations (number migration)

Activation relates to the number migration of your services (if applicable) when your product is first installed.

The activation is performed in three phases (described below) with an option to go back (roll back), which returns both outgoing and incoming migrations, depending how far you may have progressed.

IMPORTANT: When you begin the migration or roll back your services **you must** also move the PBX cabling between the NT1 and SIP NTU accordingly. **When you do this, you will experience a disruption in service until the Activation (number migration) is finalised.**

The migration phases are:

1. **Outgoing** – enables the outgoing call capability and allows you to test your outgoing calls, with an option to roll back. This is also required to perform NTU test calls, described in section 6.9.
2. **Incoming** – migrates incoming calls and allows you to perform tests, again with an option to roll back.
3. **Finalise** – begins a seven-day trial period to evaluate your services in daily operation, within which time you can either roll back using the Customer Management Portal interface or with assistance from Telstra support, where the rollback option isn't presented. **Note:** Telstra support can only help with rolling back your services during the seven-day 'soak' period.

* The three rollbacks mentioned above are cumulative across phases **2. Incoming** and **3. Finalise**.



TELSTRA BUSINESS SIP®

7.2.1. Rolling back your migration

Once you've activated the **Outgoing**, **Incoming** and **Finalise** phases, the **Rollback** option on the **Finalise** box remains available for up to seven days, depending on how many rollbacks are performed during the migration. This seven-day period allows time to assess the operational performance of your Telstra Business SIP services.

Between the **Incoming** and **Finalise Activation** steps there is a limit of three rollbacks*, after which the rollback option is not presented.

7.2.2. Number migration test calls

During the number migration, test calls are required to evaluate whether to roll back or activate the next phase.

Outgoing test calls must be made from the handsets connected to the PBX associated with your Telstra Business SIP product. It is recommended that calls be made to different types of networks, including but not limited to, mobile (on different carriers), local standard numbers and interstate numbers.

Incoming test calls – arrange calls from mobiles (on different carriers), local standard numbers, interstate and (if relevant) international numbers.

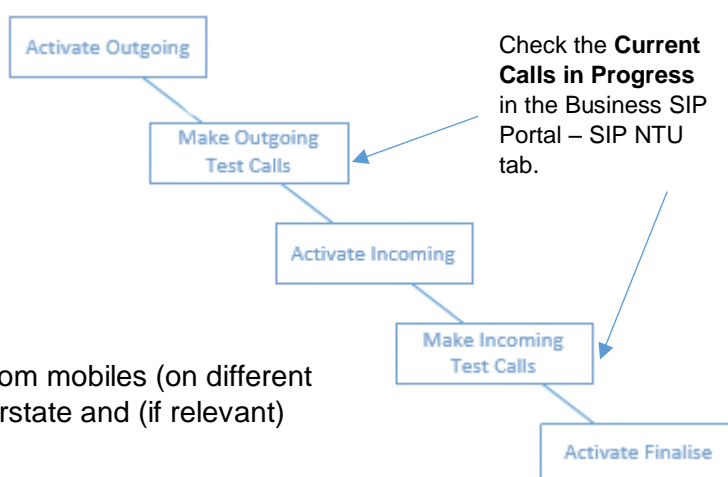
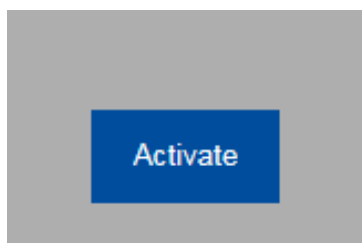

Figure 46: Migration process flow and test points

Below are the five status indicators you'll see during the migration process.

Note 1: The second and third states are transitional and may only appear briefly.

Note 2: During the process the web GUI will take 5 minutes to update, however it is likely that the initiated changes have taken place and so testing (in the case of Outgoing Call activation) may be started even though the web page indications may not have changed.



Pending Phase

This indicates that the phase (outgoing, incoming or finalise) is ready to start migrating.

Click **Activate** to begin the migration phase.

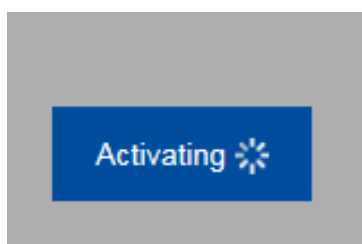

Phase Initiated

This status appears momentarily while the migration is started.

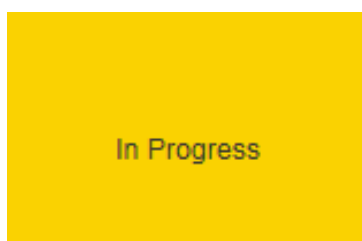

Phase in Progress

This status appears during the setting up of services in the background.

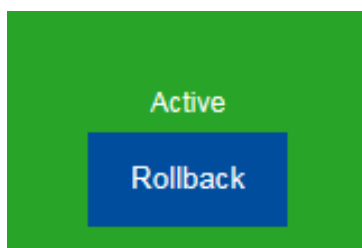

Phase Completed – with option to undo

When this status is presented, you can start testing your calls for the given phase of the migration.

If successful, click **Activate** on the next phase or click **Rollback** to begin again.

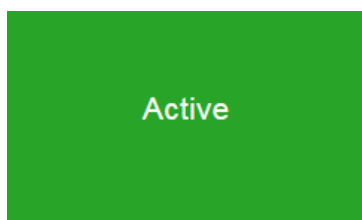

Phase Completed – with no option to undo

These will be repeated for each of the three phases, noting that the second and third are transitional.

7.2.3. Activation (number migration) process

Select the **Activations** tab to start the number migration process.

If there are no orders pending you will see the message:

“You currently have no outstanding orders for number migration.”

Where an order **is** pending, the following screens describe:

- how you can check the affected numbers to be migrated
- the process, with text describing the required interactions.

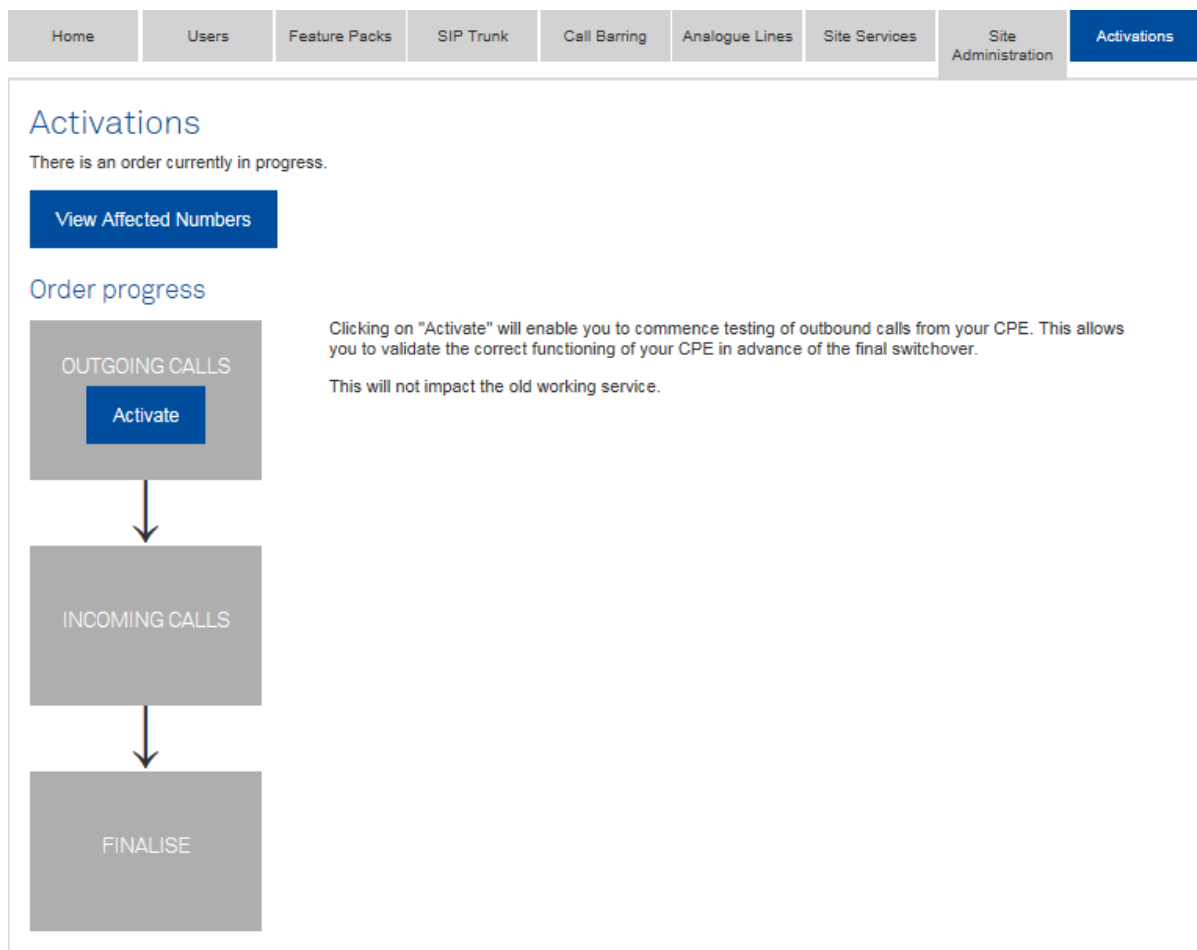

Figure 47: Activations (number migration) tab



TELSTRA BUSINESS SIP®

Before you begin the migration, you can view the numbers being migrated by selecting the **View Affected Numbers** button as shown below:

The screenshot shows the 'Activations' section of the Telstra Business SIP interface. A red arrow points from a callout box to the 'View Affected Numbers' button. The callout box contains the text: 'Click here to view the affected numbers via a pop-up window.' Below the button is an 'Order progress' section with a flowchart: 'OUTGOING CALLS' (with an 'Activate' button) -> 'INCOMING CALLS' -> 'FINALISE'. A text box explains: 'Clicking on "Activate" will enable you to commence testing of outbound calls from your CPE. This allows you to validate the correct functioning of your CPE in advance of the final switchover. This will not impact the old working service.' The 'Affected Numbers' pop-up window is shown in the foreground, displaying a table of impacted services. The table has columns for 'Interface', 'Variant', 'Ports', and 'Numbers'. The numbers listed are: 03 7064 2100, 03 7064 2111, 03 7064 2122, 03 7064 2133, 03 7575 9621, 03 7575 9633, 03 3519 8300 - 03 3519 8399, 03 2805 8450 - 03 2805 8459, and 03 2438 2000 - 03 2438 2099. A 'Close' button is at the bottom left of the pop-up. The text 'SAMPLE ONLY' is overlaid on the pop-up.

Interface	Variant	Ports	Numbers
PSTN	MULTIPLE NUMBER	1	03 7064 2100
			03 7064 2111
			03 7064 2122
			03 7064 2133
PSTN	FAX DUET	1	03 7575 9621
			03 7575 9633
ISDN PRI	INDIAL	1	03 3519 8300 - 03 3519 8399
			03 2805 8450 - 03 2805 8459
			03 2438 2000 - 03 2438 2099

Figure 48: View Affected Numbers pop-up

Once you've reviewed this information click .



Before you start your activation you'll see this screen with **Activate** in the **Outgoing Calls** box as shown below:

Home Users Feature Packs SIP Trunk Call Barring Analogue Lines Site Services Site Administration **Activations**

Activations

There is an order currently in progress.

[View Affected Numbers](#)

Order progress

OUTGOING CALLS

Activate

INCOMING CALLS

FINALISE

Clicking on "Activate" will enable you to commence testing of outbound calls from your CPE. This allows you to validate the correct functioning of your CPE in advance of the final switchover. This will not impact the old working service.

Click **Activate** to begin the outgoing call migration. You will see the pop-up to confirm your action.

Message from webpage

Are you sure you would like to proceed to activate?

OK Cancel



The outgoing calls box will appear yellow for a brief period as the changes are made in the background.

Home	Users	Feature Packs	SIP Trunk	Call Barring	Analogue Lines	Site Services	Site Administration	Activations
------	-------	---------------	-----------	--------------	----------------	---------------	---------------------	-------------

Activations

There is an order currently in progress.

[View Affected Numbers](#)

Order progress

You have requested outbound calling to be activated.

```
graph TD; A[OUTGOING CALLS  
In Progress] --> B[INCOMING CALLS]; B --> C[FINALISE];
```

Once the Outgoing calls have been migrated the button will turn green with **Rollback** in a blue box, as shown in the next image.



TELSTRA BUSINESS SIP®

Once the outgoing calls have been activated you'll see the **Rollback** option appear as shown below, plus the **Activate** option on the incoming calls. Using PBX handsets, perform outgoing test calls to landlines, mobiles, interstate numbers (the types you'd use during normal operation).

Home Users Feature Packs SIP Trunk Call Barring Analogue Lines Site Services Site Administration **Activations**

Activations

There is an order currently in progress.

[View Affected Numbers](#)

Order progress

OUTGOING CALLS
Active
[Rollback](#)

INCOMING CALLS
[Activate](#)

FINALISE

You have activated outbound call testing. You may commence testing from your CPE. You have until tonight to test and move on to the next phase or rollback will be automatically performed.

At this point the old working service is not impacted.

You can manually roll back if needed. You can also perform limited inbound testing. This can be achieved by assigning an extension number, on this portal, against any of your numbers. A call from your CPE to this extension number, if offered up the SIP service, will come back as an inbound call.

If you are happy with outbound call testing you can proceed to full inbound testing. Note it may take 5 to 45 minutes or more to process all the network changes for inbound.

So at this point you have **two** choices:

1. Click **Rollback** to undo the outgoing call migration and you will see this message:

Or

2. Click **Activate** to begin the migration of the incoming calls, in which case you will see this message:

Message from webpage: Are you sure you would like to roll back?

Message from webpage: Are you sure you would like to proceed to activate?

Selecting to **Activate** migration for incoming calls presents the **In Progress** (transitional) status as shown below:



Activations

There is an order currently in progress.

[View Affected Numbers](#)

Order progress



You have requested activation of inbound call testing. Commence testing from Telstra Mobiles and Telstra VoIP-based services (e.g. TIPT, SIP Connect, DOT, NBN). Temporary migration of legacy fixed services and other service provider services could take 5 to 45 minutes or more to process.

You have one week from tonight to test before finalisation occurs. Your old service will be cancelled after finalisation.

Once full activation is in place, you can manually roll back if needed. Rolling back will cancel the pending finalisation.

Note: The INCOMING CALLS **Activating** (transitional) status has been omitted for clarity.



Once the incoming calls have been activated you'll see the **Rollback** option appear as shown below, as well as the **Activate** option on the **Finalise** step. Using external services including mobiles from various carriers, landlines, interstate landline residential and business numbers, arrange calls into the PBX:

Home	Users	Feature Packs	SIP Trunk	Call Barring	Analogue Lines	Site Services	Site Administration	Activations
------	-------	---------------	-----------	--------------	----------------	---------------	---------------------	-------------

Activations

There is an order currently in progress.

[View Affected Numbers](#)

Order progress

Inbound calling is now fully active. The old service will no longer be receiving calls.

If call testing is 100% successful for all call types you can move into the next phase by either clicking the finalise button or doing nothing, in which case finalisation will be automatic.

You have one week in the finalisation phase. At the end of the week, when the point of no return is reached, you will no longer be able to roll back and the old service will be cancelled.

If some call types are not working it is recommended that you roll back and initiate actions to repair.

Roll back covers both outbound and inbound.

Selecting to **Activate** migration for **Finalise** presents the **In Progress** (transitional) status as shown below:



Activations

There is an order currently in progress.

[View Affected Numbers](#)

Order progress



You have initiated the finalisation sequence. You have 1 week to soak test the service before the roll back option will be removed.

After the week, when the point of no return is reached, your old service will be cancelled. If the week started on Friday, Saturday or Sunday, then the point of no return will be postponed until the following Monday night (1 week and 3, 2 or 1 days, respectively).

Roll back applies to both outbound and inbound.

Note: The Activating (transitional) status has been omitted for clarity.



Activations

There is an order currently in progress.

[View Affected Numbers](#)

Order progress

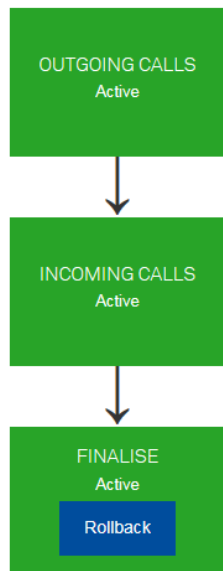

At this point your services are fully migrated; however once **Finalise** goes to the **Active** state, the **Rollback** option is presented for seven days.

Note: If you've already used the rollback function three times during the incoming and finalise phases, the rollback option will not be presented.

If you need to roll back your services during the seven-day period, contact us.

Where assistance is required contact Telstra on [\(1800 790 831\)](tel:1800790831).



TELSTRA BUSINESS SIP®

At the end of the seven-day soak period your migration will be complete and you will be advised as presented below:

Activations

There is an order currently in progress.

[View Affected Numbers](#)

Order progress

You have completed the 1 week to soak test. The point of no return has passed and your old service is in the process of being cancelled. Roll back is no longer possible.

```
graph TD; A[OUTGOING CALLS  
Active] --> B[INCOMING CALLS  
Active]; B --> C[FINALISE  
Active];
```

When you see this screen, your old services will be decommissioned.

8 Appendices

These appendices include supplementary information to assist in the management of your Business SIP product during installation and operation.

8.1. SIP NTU Diagrams & Connections

The following diagrams present the various connections and visual indicators for the NTU models accredited for use with Business SIP.

8.1.1. 2515 IP PBX only

Front Interfaces View

The following figure shows the front panel of One2515 with Ethernet and ADSL/VDSL WAN interfaces:

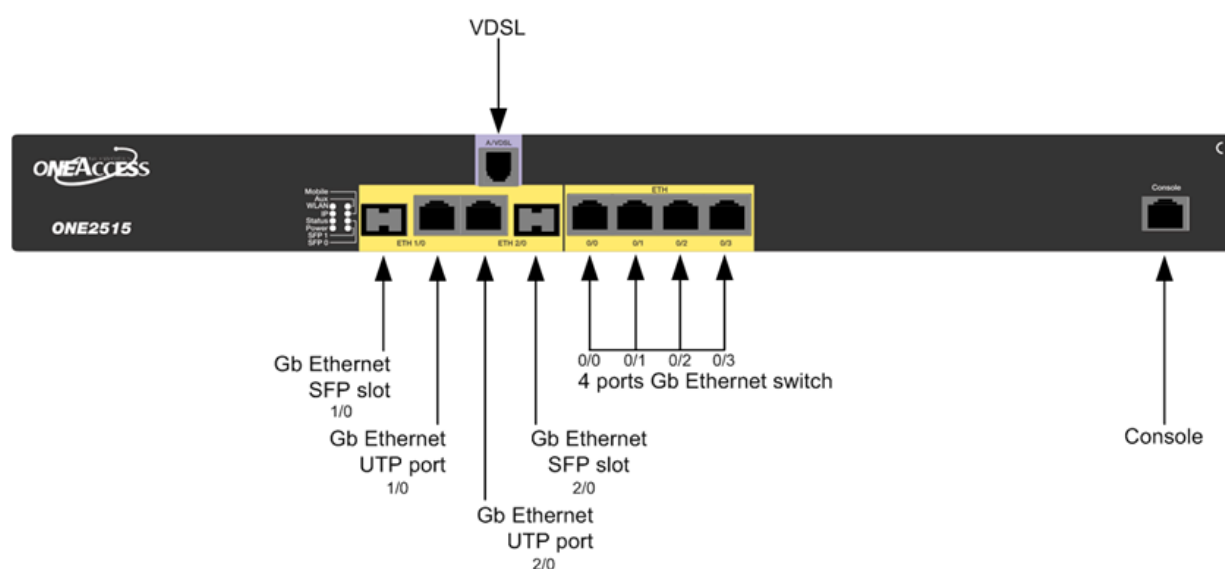
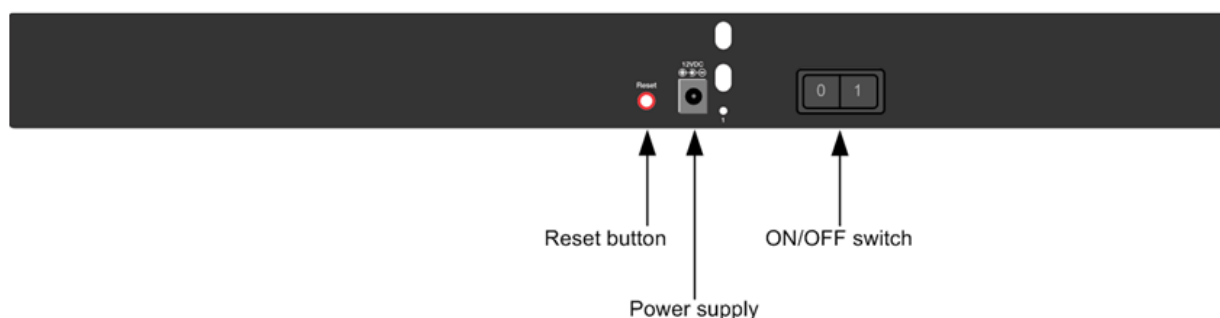

Figure 49: One2515 Series Front View

Rear Panel Status Indicator

The following figure shows the back panel of One2515:



8.1.2. 270 IP & ISDN PBX

Front View



Figure 50: One270 front view

Rear View

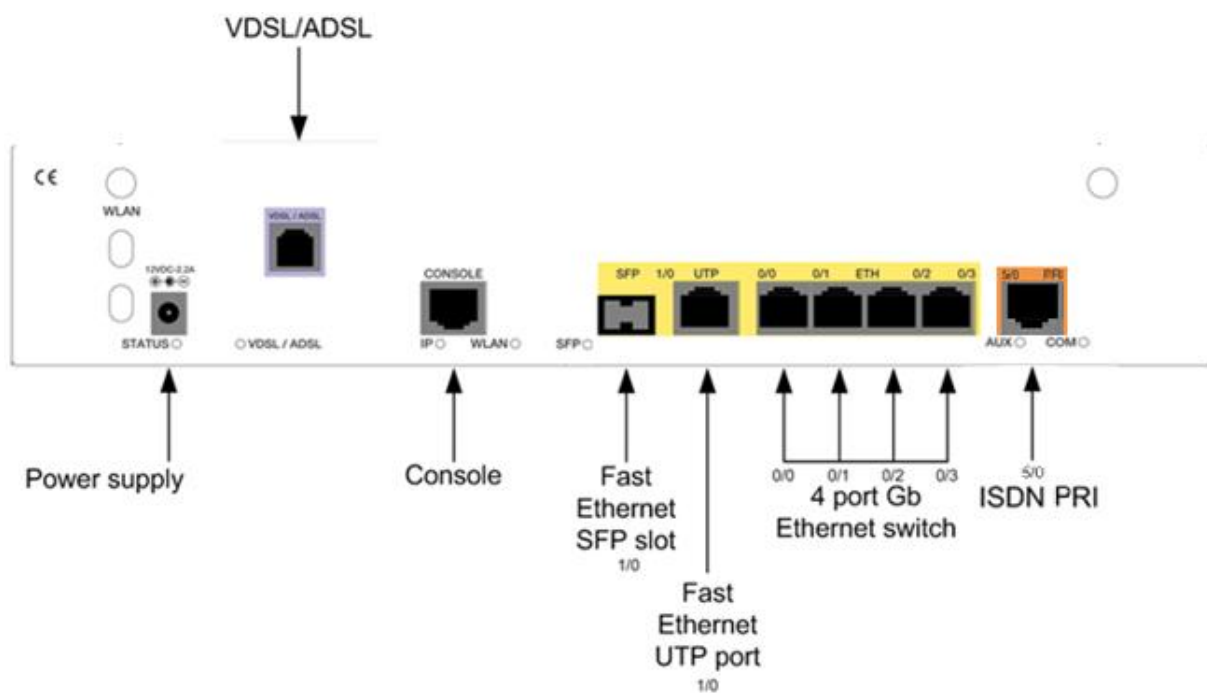

Figure 51: One270 1P AV2 5T/a rear view

8.1.3. 420 IP PBX only

Front View

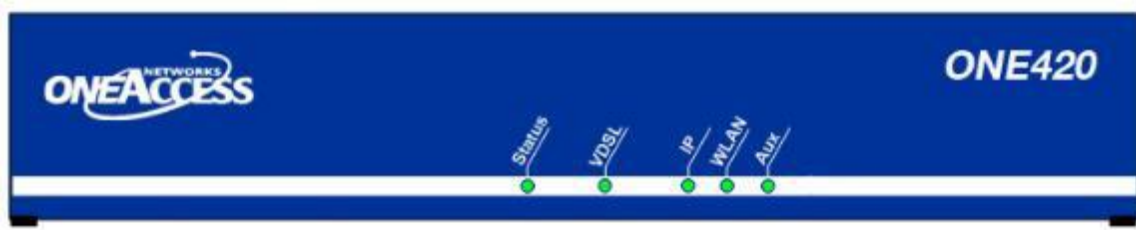

Figure 52: One420 Series Front View

Rear View

The following figure shows the back panel of One420 with Ethernet and ADSL/VDSL WAN interfaces:

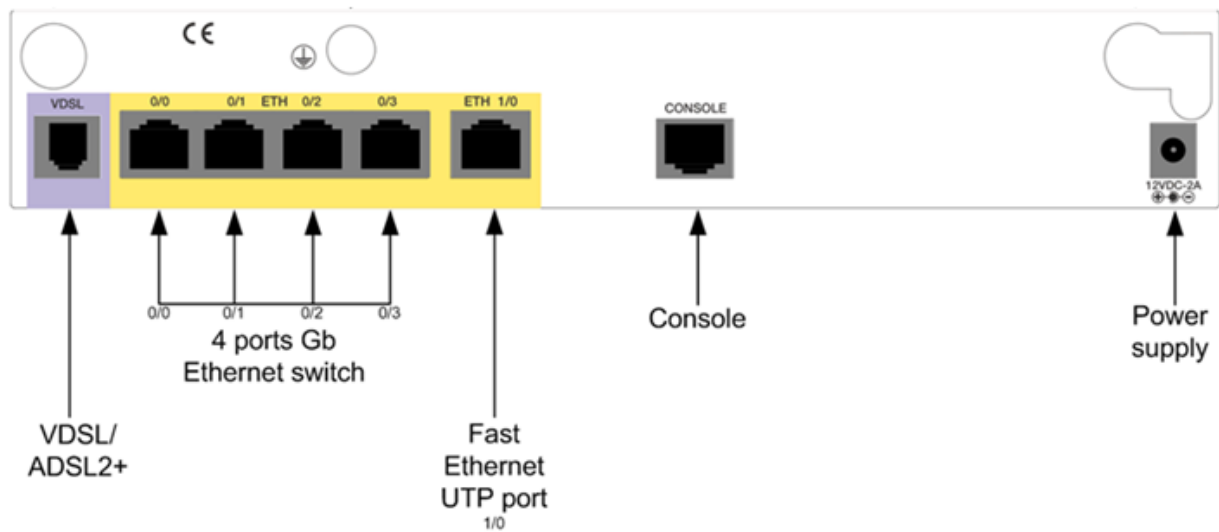

Figure 53: One420 AV2 4TE Rear View

8.1.4. 425 IP PBX only

Front View

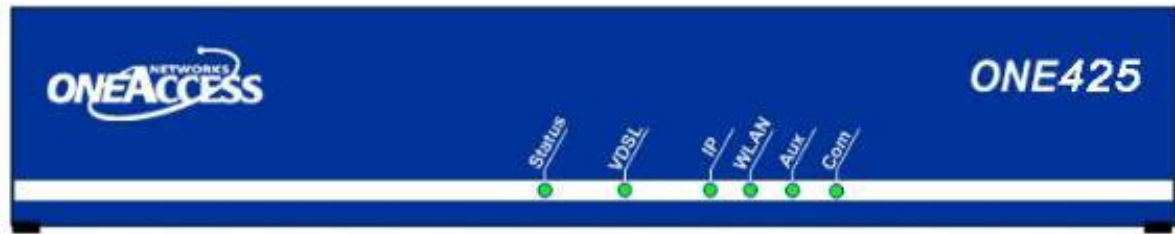

Figure 54: One425 Series Front View

Rear View

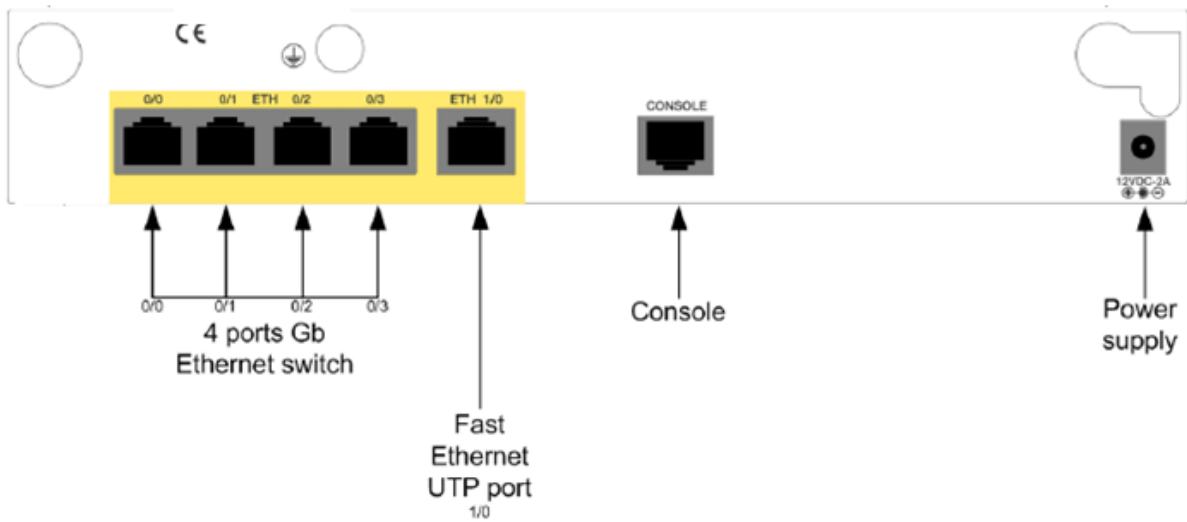

Figure 55: One425 4TE rear view

8.1.5. 425 4B 4TE IP & ISDN PBX

Front View

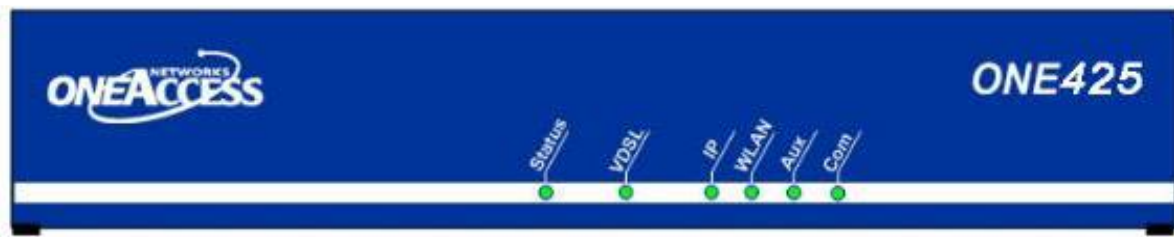

Figure 56: One425 Series Front View

Rear View

The following figure shows the back panel of OE425 with Ethernet WAN interface:

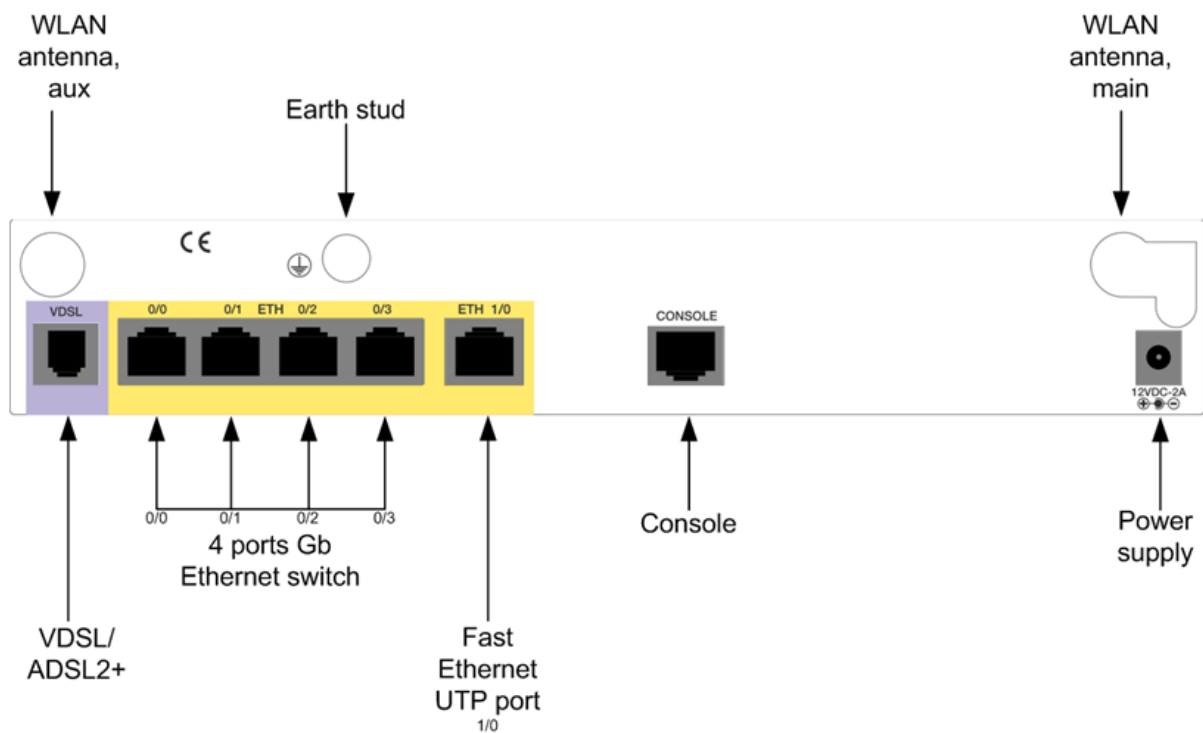

Figure 57: One425 4TE Rear View

8.1.6. 540 IP PBX only

Front View

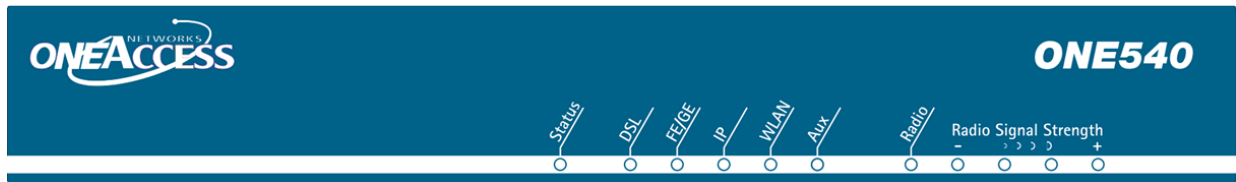

Figure 58: One540 Series Front View

Rear View

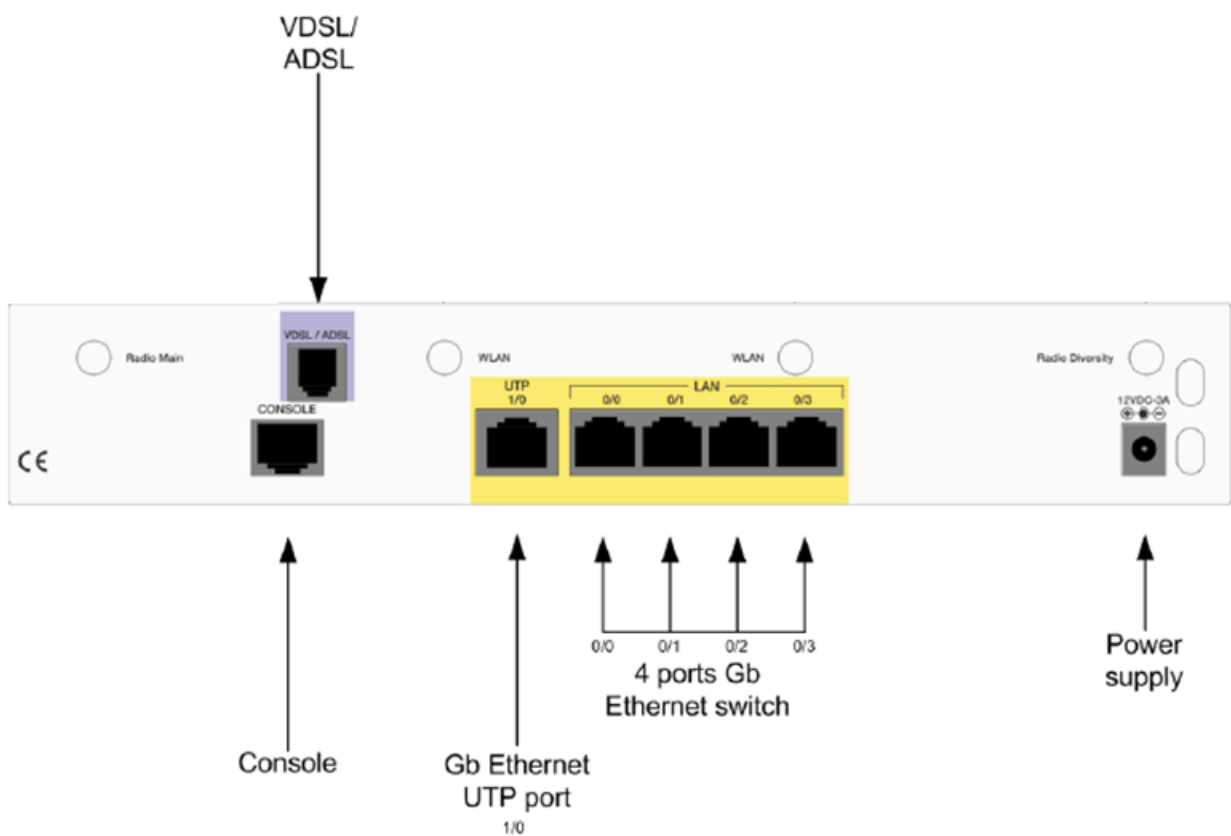

Figure 59: One540 AV2 5TE/a Rear View

8.1.7. 700 IP & ISDN PBX

Front View



Figure 60: One700 front view

Rear View

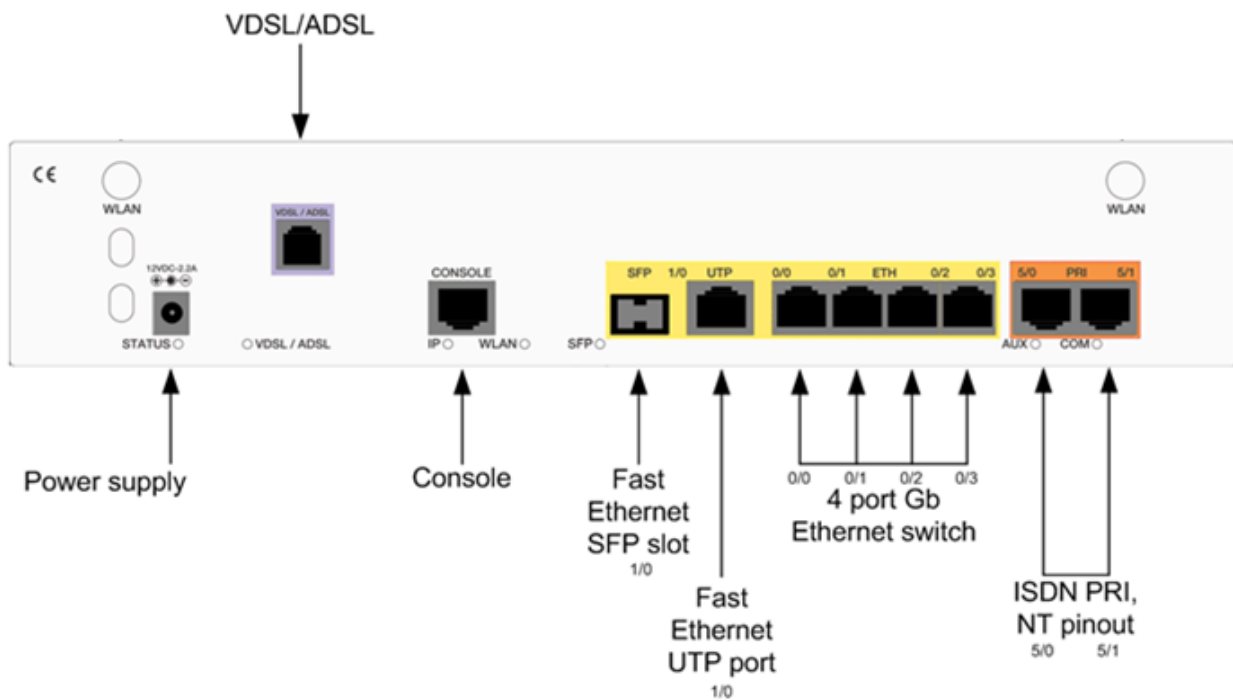

Figure 61: One700 2P AV2 5T/a rear view

8.2. Appendix - Retrieving NTU Device ID and password

To retrieve the Business SIP Platform device ID and password (also referred to as ‘device credentials’, log in to the Business SIP Customer Management Portal (<https://portal.mycalling.telstra.com/login> using your Administrator username and password) and

navigate to the **SIP Trunk** tab then select **SIP NTU** SIP NTU as shown below.

The device ID and password can be accessed by clicking ‘**Get Credentials**’ as shown in the screen below:

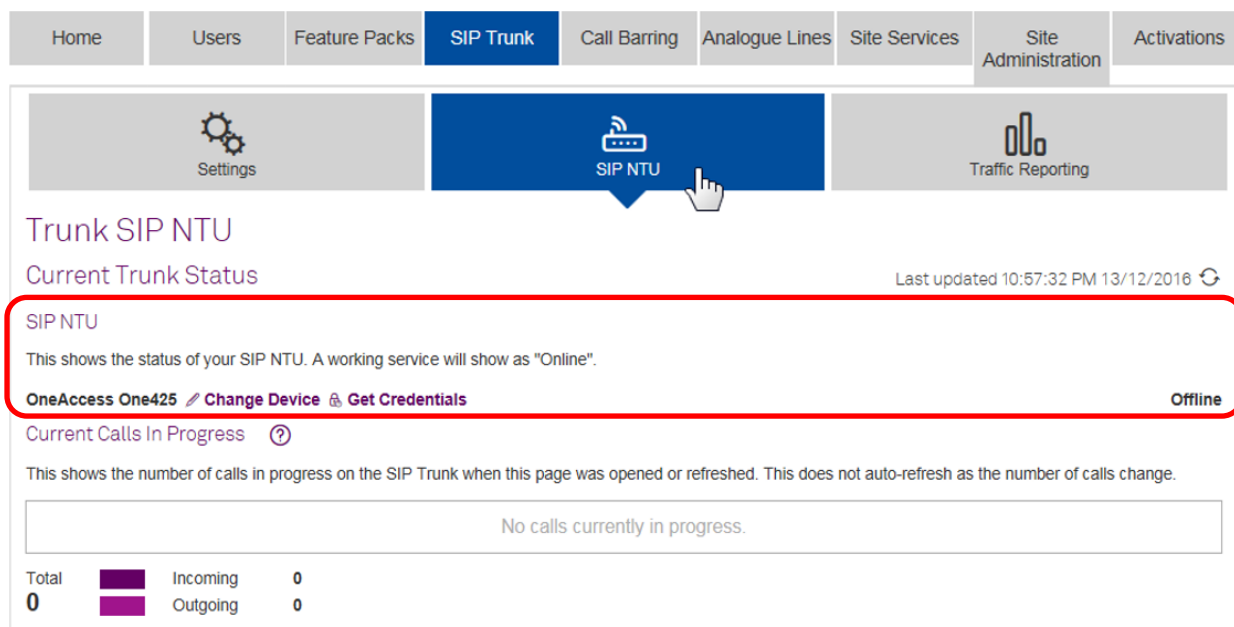

Figure 62: Get Credentials link in SIP NTU tab

Clicking ‘**Get Credentials**’ opens a pop-up window presenting the username and password.

Note: Keep these details strictly confidential as the integrity of your device and the security of your service depends on this information.

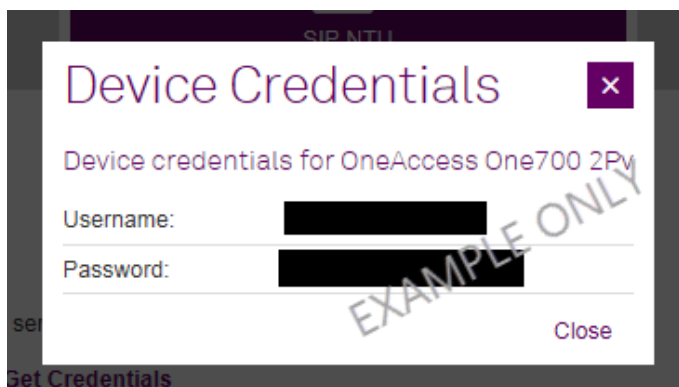

Figure 63: ‘Get Credentials’ pop-up example

8.3. Appendix - Troubleshooting

The following information may assist during installation or configuration. Use the table below to resolve or triage any basic issues before requesting assistance. Take note of what step you were up to when you identified an issue as it could help to identify the possible cause.

Step	Problem	Action	Resolution
1	The unit has been delivered but it may not be the correct device.	Check the paperwork that came with the device against the customer order.	If the product code does not match, follow the process described in: 8.5 Appendix – Faulty hardware
2	Inspection of contents to confirm that no parts are missing.	Check that the device, the power cord and the Ethernet cable are in the box.	If device or power cord are missing, follow the process described in: 8.5 Appendix – Faulty hardware
3	The unit may be damaged.	Inspect the casing and interface ports.	If damaged, follow the process described in: 8.5 Appendix – Faulty hardware
4	The Ethernet cable doesn't work.	Try another Ethernet cable to prove.	Replace the Ethernet cable as required.
5	The power pack doesn't work.	Plug into an alternative wall socket and check the SIP NTU STATUS LED is on.	If still not working follow the process described in: 8.5 Appendix – Faulty hardware
6	The SIP NTU login screen doesn't present.	Check that the SIP NTU STATUS LED is green. Check that the IP address has been entered correctly in the browser. See section 5.1 SIP NTU login .	If the SIP NTU STATUS LED is not Green, contact Telstra Support. Refer to 8.5 Appendix – Faulty hardware
7	The SIP NTU log in - details fail.	Check that the serial number of the device has been correctly entered. (It is case sensitive). See section 5.1.1 SIP NTU username and password .	If the SIP NTU log in - web credentials still don't work, contact Telstra Support. Also refer to 8.5 Appendix – Faulty hardware
8	The provisioning wizard detects. An incorrect WAN interface.	Check that the PC/laptop is connected to the correct port (LAN port 02 or 03), check the cable, and re-run the WAN detection procedure.	The wizard detects the correct WAN interface, if not contact Telstra Support.
9	SIP NTU Device ID and password not accepted.	Review section 5.1.1 SIP NTU username and password	Contact the Support team to check the Device ID and password.

Step	Problem	Action	Resolution
10	Device ID and password are accepted but the SIP NTU doesn't register.	<p>Perform a Factory Reset of the NTU (see section 6.10.4)</p> <p>After the device has rebooted, restart the Provisioning Wizard in the GUI.</p> <p>Reconfirm the SIP NTU registration. Check GUI (see Figure 14)</p> <p>Recheck device LEDs as per the tables in section 8.4 Appendix - SIP NTU LED functions</p>	If device still not registered after Factory Reset contact Telstra Support.

Telstra Business SIP® Support - (1800 790 831)

8.4. Appendix - SIP NTU LED functions/colour indicators

The table below explains the meaning of each SIP NTU LED. Use this to determine action required to resolve issues or to pass on related information to Telstra support.

LED name	Colour	Description
Status	OFF	No input power.
	Green	Steady green: Device is switched on and operational. Blinking green: Device reboot is in progress.
	Red	Steady red: Device is switched on but not operational.
VDSL (Where applicable)	Steady Green	Access OK, normal operation
	Steady Red	Possible internet access related issue.
	OFF	Possible internet access related issue
IP	Green	WAN/internet connection OK
	Red	WAN/internet connection faulty
WLAN	Not used	
AUX	OFF	The auto-update procedure has not started.
	Green	Steady green: The auto-update procedure is completed and ISDN layer 1 has been recognised. After a few seconds, the SIP NTU registers and the light goes solid green. Provisioning can be started.
	Orange	Blinking orange: The auto-update procedure is in progress. The SIP NTU is not ready for operational use.
	Red	Steady red: There is an auto-update configuration error. The DMS cannot synchronise with the SIP NTU. Blinking red: The auto-update procedure has failed or there is an internet connection issue.
COM	OFF	The SIP NTU is not configured.
	Green	Steady green: The northbound SIP NTU is registered. There is no call in progress. Blinking green: A voice call is in progress on one of the voice ports.
	Red	Steady red: Either ISDN layer 2 of the ISDN ports is down or the SIP gateway registration failed.

8.5. Appendix – Faulty hardware

In the event that a device does not power up or fails to register, **Customer-nominated technician/Telstra nominated partners** should contact Telstra on **(1800 790 831)** to confirm the device condition. The support staff can assist with arranging a replacement device if needed.

Telstra technicians should follow Telstra internal procedures.

9 Glossary

Term	Definition
BRA/BRI	Basic Rate Access (BRA)/Basic Rate Interface (BRI) Refers to “BRI” in the OneAccess SIP NTU GUI.
CPE	Customer premises equipment
Device credentials	Refers to the username/password required to access the Business SIP Platform server to download the configuration file for the SIP NTU.
DHCP	Dynamic host configuration protocol
DMS	Device Management Server – Containing the SIP NTU configuration files
IP	Internet protocol
HTTP	Hypertext transfer protocol
NAT	Network address translation
Northbound	OneAccess term which defines the area towards the telco network from the SIP NTU
NTU	Network termination unit
PRA/PRI	Primary Rate Access (PRA)/Primary Rate Interface (PRI) Refers to “PRI” in the OneAccess SIP NTU GUI.
SIP	Session initiation protocol
Southbound	OneAccess term which defines the area towards the customer network from the SIP NTU to the PBX